

INSTALLATION, OPERATION AND MAINTENANCE INSTRUCTIONS

238 - Wellglass Luminaires

ATEX & IECEx

Important:

Please read these instructions carefully before installing or maintaining this equipment. Good electrical practices should be followed at all times and this data should be used as a guide only.

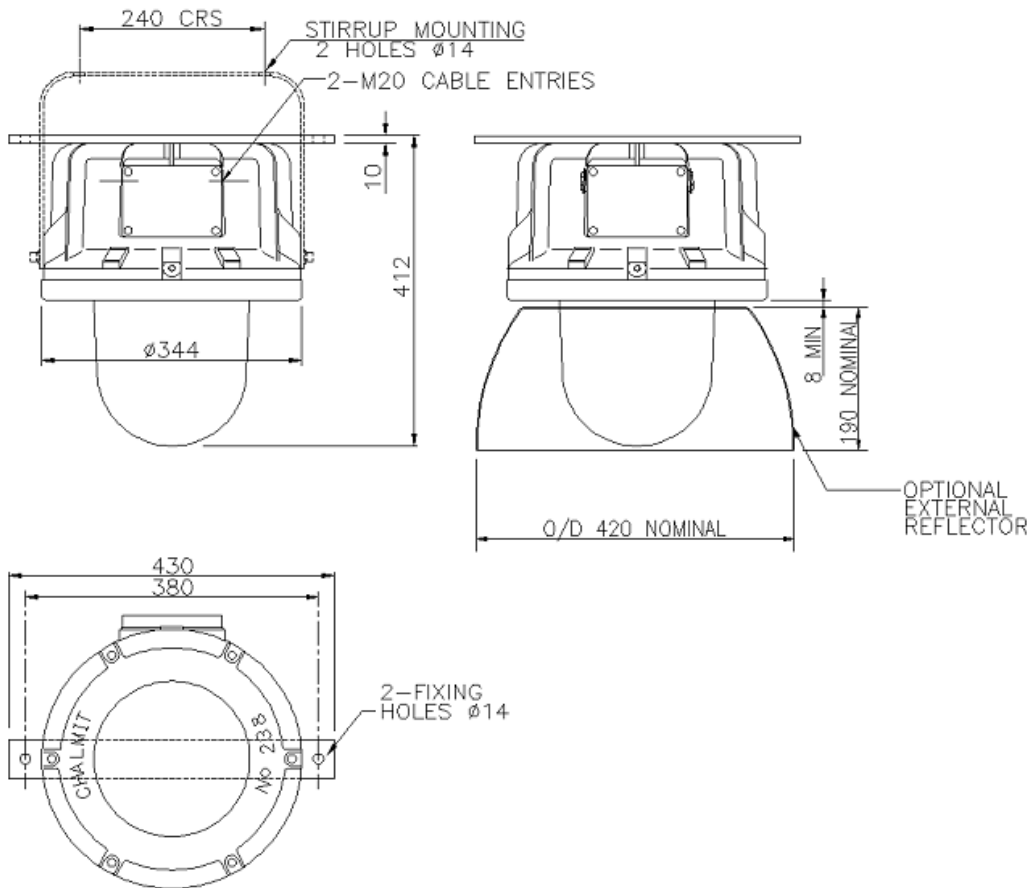

WEIGHT	150W SON/E	250W SON/E	200W GLS
ALUMINIUM	21.6 Kg	24.2 Kg	18.4 Kg

WINDAGE AREA: 0.11m²

WINDAGE AREA WITH OPTIONAL EXTERNAL REFLECTOR: 0.15m²



0.0 Specification

Type Of Protection	Ex de (flameproof and increased safety), Ex tD (dust)
Protection Standards	IEC60079-0:2007 / EN60079-0:2006 , IEC60079-1: 2007 / EN60079-1:2007, IEC60079-7:2006 / EN60079-7:2007, IEC/EN 61241-1:2004
Area Classification	Zone 1 and Zone 2 areas to EN/IEC 60079-10 and installation to EN/IEC 60079-14 Zone 21 and Zone 22 areas to EN/IEC 61241-10 and installation to EN/IEC 61241-14
Certificate	IEC certificate of conformity IECEx BAS08.0056 EC type examination certificate Baseefa08ATEX0177
Equipment Coding	⊕ Ex de IIB T3/T4/T5 T°C ≤ Ta ≤ T°C (see table for details) Ex tD A21 IP66 T°C (see table for details)
ATEX Coding	⊕ II 2GD
Ingress Protection	IP66 to EN/IEC 60529
CE Mark 	The CE marking of this product applies to "The Electrical Equipment (Safety) Regulations 2006", "The Electromagnetic Compatibility Regulations 2004", the "Waste Electrical and Electronic Equipment Regulations 2006" and the "Equipment and Protective Systems intended for use in Explosive Atmospheres Regulations 1996". [This legislation is the equivalent in UK law of EC directives 2006/95/EC, 2004/108/EC and 2002/96/EC respectively].
ATEX Declaration	The Equipment is declared to meet the provisions of the ATEX directive (94/9/EC) by reason of the EC Type Examination and compliance with the Essential Health and Safety Requirements. I MacLeod Technical Manager

SPECIAL CONDITIONS FOR SAFE USE

None

1.0 Introduction - 238 Wellglass Luminaire.

The type 238 Wellglass Luminaire is designed for all round and high bay applications. It is suitable for use with elliptical discharge lamps and GLS incandescent lamps and QL lamp sources. An external reflector is available.

Note: Lamp ranges and temperature ratings are outlined in TABLE 0. The wellglass is certified down to -50°C.

2.0 Storage

Luminaires and control gear boxes are to be stored in cool dry conditions preventing ingress of moisture and condensation. Any specific instructions concerning emergency luminaires must be complied with.

3.0 Installation and Safety

3.1 General

There are no health hazards associated with this product whilst in normal use. However, care should be exercised during the following operations. Installation should be carried out in accordance with EN/IEC 60079-14 or the local hazardous area code of practice, whichever is appropriate, and fitting of specified insulating material to be adhered to where a specific fire resistance rating is required.

In the UK the requirements of the 'Health and Safety at Work Act' must be met.

Handling and electrical work associated with this product to be in accordance with the 'Manual Handling Operations Regulations' and 'Electricity at Work Regulations, 1989'. Your attention is drawn to the paragraphs

- (i) 'Electrical Supplies',
- (ii) 'Electrical Fault Finding and Replacement' and

(iii) 'Inspection and Maintenance'. The luminaires are Class 1 and should be effectively earthed.

The luminaires are quite heavy and suitable means of handling on installation must be provided. Guards can be supplied with or fitted retrospectively to protect glass if there is a higher than normal risk of mechanical damage. This wellglass luminaire has passed thermal shock testing during certification, it is still advisable to mount the wellglass in locations to reduce the possibility of thermal shock.

Certification details on the rating plate must be verified against the application requirements before installation.

The information in this leaflet is correct at the time of publication. The company reserves the right to make specification changes as required.

3.1.1 Use in Combustible Dust Atmospheres

Where the equipment is used in ignitable dust atmospheres reference must be made to the selection and installation standards in order that the equipment is used correctly. In particular this applies to the de-rating of surface temperature for use where dust clouds may be present. Dust layers should not be allowed to accumulate on the fitting surface and good housekeeping is required for safe operation. Dust in layers has the potential to form ignitable clouds and to burn at lower temperatures. Refer to EN/IEC 61241-14 for additional details of selection and installation.

3.1.2 Hybrid Mixtures – Gas and Dust

Where hybrid mixtures exist as a potentially explosive atmosphere, consideration should be given to verifying that the maximum surface temperature of the luminaire is below the ignition temperature of the hybrid mixture.

3.2 Tools

8, 6, 5mm A/F socket keys.
3mm and 5mm flat blade screwdriver, 19mm A/F spanner.
Suitable spanners for installing cable glands.
Pliers, knife, wire strippers/cutters.

3.3 Electrical Supplies

The supply voltage and frequency should be specified when ordering. A maximum voltage variation of +6%/-6% on the nominal is expected. (The safety limit for T rating is +10%). Luminaires should not be operated continuously at more than +6%/-10% of the rated supply voltage of the control gear or tapping. The user must determine the **actual** underlying site supply and purchase or adjust accordingly. **Care must be taken in connecting to the nominal 230V UK public supply.** In most cases, the luminaire has multi-tapped control gear which can be set to a range of voltages on 50 or 60Hz cycles. The tapings are shown on the control gear and the

limits are shown on the rating plate. If the equipment is located in high or low voltage sections of the system, an appropriate voltage tap should be selected, but care must be taken to log or mark the equipment so that the tapping is re-set if the equipment is re-located. If in doubt, tapings should be set on the high side. 20V max. nominal drop is acceptable for incandescent and MBF, 10V max. drop is desirable for HPS and Metal Halide(MH). The light output will be reduced. The HPS/MH circuits use S.I.P ignitors and the circuit diagram will indicate the choke connections. Where shore or construction site supplies are used, different to the service supplies, tapings should be re-set. If not, advice on the effect of these temporary supplies should be sought from the Technical Department. Where adverse system conditions occur, luminaires can be supplied without PFC. The circuit current will then be the lamp current. The circuit power does not change. Incandescent lamps must be selected for the supply voltage. Running at over the rated supply voltage will reduce life and at greater than +10% will compromise the T rating.

3.4 Lamps

The lamps used in this range are of a standardised type and there is no preference between makes, or in the case of HPS, colour. The MBI 250W is the 3.0A type. Due to the need to control photometric performance and certification conditions, and avoid incorrect lamps being fitted, the type of lamp and size is specified on the rating plate. If mixed installations are used, care must be taken to ensure that the correct lamp is fitted on installation and replacement. GLS lamps will give 1000 hours life dependent on the supply voltage variation. The light output will remain substantially unaltered up until failure. Mercury vapour lamps will burn for up to 24,000 hours but should be changed at 10,000 as they will then be at about 70% of

initial output. HPS/MH lamps substantially maintain their light output to the end of their electrical half life, which again can be up to 24,000 hours. However, lamp replacement at around 16,000 hours is desirable to avoid piecemeal replacement on a large scale. **HPS and MBI lamps should be replaced shortly after they do not light.** One indication of the end of life for HPS lamps is 'cycling' where the lamp goes out then re-ignites after a minute or so interval. If discharge luminaires are burned continuously they should be switched off occasionally, to allow old lamps to fail to re-ignite rather than possibly become diodes with detrimental effects on control gear. The above information is current at the time of publication. The development of lamps and control gear is ongoing and detailed advice on lamp performance can be obtained from the Technical Department or the lamp supplier. **HPS and MBI circuits should not be energised without a lamp fitted.** In general, HPS lamps without internal ignitor should be used. The current HPS control gear is incompatible with internal ignitor lamps. GES (E40) 125W Mercury Vapour lamps should be used as standard.

3.4.1 QL Lamps

The QL lamps available for this product are 55W, 85W and 165W types. The QL lamp will operate for up to 60,000 hours dependant on operating ambient. The QL lamp system consists of a lamp, power coupler that the lamp fixes to and a HF generator. Should the lamp fail to ignite it is most probable that the HF generator will need replacement, please note that it is essential that the correct generator be fitted. Contact the technical department for advice.

3.4.2

When a QL lamp source is fitted the fitting may be sealed for life by applying silicone sealant on flamepath (maintaining flamepath gap). This would also require the

cover bolts to be filled with a hard setting epoxy resin and a label stating that the front cover must not be removed will be attached to the luminaire.

3.5 Mounting

Luminaires should be installed where access for maintenance is practical and in accordance with any lighting design information provided for the installation. This will usually consist of aiming points and aiming angles.

The top mounting or trunnion mounting arrangements should be secured with lock washers or self-locking nuts and bolts.

3.6 Cabling and Cable Glands

3.6.1 Cable Glands

The installer and user take responsibility for the selection of cables, cable glands and seals. The product is certified for ATEX and to comply with the certification for installation and use within the EU, cable glands and sealing plugs must be ATEX certified. For installation outside the EU, suitable cable glands in accordance with IEC 60079-0 will meet the technical requirements.

Cable glands for entry into Ex e enclosures when fitted with any gland to body sealing method and the supply cable must reliably maintain the IP rating of the enclosure (IP66) with a minimum value of IP54. The cable gland must withstand an impact value of 7Nm or 4Nm where the risk of mechanical damage is low. Sealing plugs must be similarly rated and a tool must be used for their removal. Where the cable is not reliably clamped externally to the apparatus, the cable gland must clamp the cable against a pull in Newtons of 20x the cable OD in mm for non-armoured cable and 80x the cable OD for armoured cable. Selected metal industrial cable glands may meet this requirement. Plastic cable glands must be Ex certified. Glands for metal covered mineral insulated cables must be Ex e certified. Where brass cable glands are used

in a corrosive environment nickel plating should be used. Two tapped cable entries are provided, one with a plug and seal suitable for permanent use, the other has a travelling plug. M20 x 1.5 entries are standard, other sizes are available on request.

3.6.2 Cable

At maximum rated ambient temperature refer to rating table for minimum cable temperature rating. The luminaire is also rated with the temperature rise at the cable entry. This allows the user to adjust the cable spec. for an **actual** T amb lower than that for which the luminaire is certified. The standard looping conductor size is 6mm². Internal and external earth points are provided. For luminaires specified for non-standard ambient temperatures refer to the Technical Department.

300/500V cable ratings are adequate and no special internal construction is necessary as the terminations are Ex e. The selection of cable size will be suitable for the fuse rating. Some guidance on this is given below. When MCB's are used, the type with the higher inrush current resistance, as used for motor starting and lighting, should be specified.

3.6.3 Cable Connection

The cable connections are made by removing the terminal chamber cover. The retaining screws are captive and should be re-greased as required. The conductors should be bared back so that they make full contact in the terminals, but the bare conductor should not be more than 1mm beyond the terminal. Unused terminal screws should be tightened. The core must be identified by polarity and connected in accordance with the terminal markings. Before re-fitting the cover, a final check on the correctness of connections should be made. Cover bolt torque 6Nm. Where control gear tappings need to be re-selected, the lampglass needs to be removed (see below).

Undo the three screws and extract the reflector then re-select the taps (see 'Electrical Supplies' above).

3.7 Fitting Lamps

Make sure the correct lamp is selected as detailed above. Access for fitting lamps is gained through the lampglass cover. The lampglass cover assembly should be un-bolted and suspended using suspension chain. During this operation or if the lampglass assembly is removed from the suspension chain, care must be taken to ensure no damage to the glass occurs. Take care not to hang the lampglass on one bolt when removing or replacing. Before removing the lampglass on any occasion, check that the suspension chain is secure and in good condition. The lamp should be firmly screwed into place. The flameproof path should have a coat of silicone grease (Dow Corning "Molykote III" or similar) or other protective non-setting grease suitable for high temperature. Replace all bolts and fully tighten. Torque 16Nm.

3.8 Inspection and Maintenance

Visual inspection should be carried out at a minimum of 12 monthly intervals and more frequently if conditions are severe refer to *EN/IEC 60079-17*. The time between lamp changes could be very infrequent and this is too long a period without inspection.

3.8.1 Routine Examination

The equipment must be de-energised before opening and note taken of the rated opening delay periods alternatively the nameplate may read 'do not open when an explosive gas atmosphere is present'. Individual organisations will have their own procedures. What follows are guidelines based on *EN/IEC 60079-17* and on our experience:

- 1 Ensure the lamp is lit when energised and that the lampglass is not damaged. If the glass is damaged it must

- 2 When de-energised and left to cool there should be no significant sign of internal moisture. If there are signs of water ingress, the luminaire should be opened up, dried out, and any likely ingress points eliminated by re-gasketing*, re-greasing or other replacement.
- 3 Check the terminal chamber bolts for tightness. Torque 6Nm.
- 4 Check the cable gland for tightness and re-tighten if necessary.
- 5 Check any external earthing.
- 6 Examine the lampglass for any signs of sealant damage, cracking or discoloration. If thought necessary, the silicone weather seal can be re-sealed with a proprietary brand of clear RTV silicone, but only if the underlying sealant is in good condition.
- 7 Check all cover bolts for tightness. Torque 16Nm.
- 8 Check for signs of corrosion between the lampglass cover and the main housing. Evaluation of this will be a matter for judgement gained by experience, as there may be little evidence on the outside. If there is any sign of corrosion, remove the cover and wipe the flameproof paths with a clean cloth and non-metallic scraper. Examine the surfaces for pitting; any pitted component should be replaced. A damaged or non-resilient gasket* must be replaced. The cord is 3mmØ. The cover should be re-greased with silicone (Dow Corning 'Molykote III' or similar) or other non-setting grease suitable for high temperatures, and re-fitted with all bolts fully tightened. Any replacement bolts must be identical to the original. All are 18/8 stainless steel ISO262 grade A4-70. With this type of flameproof path all bolts must

- be in place and tight. The maximum gap for IIB in this case is 0.2mm. It will be unusual for any luminaire to have a gap of more than 0.1mm when tried with a feeler gauge. If 0.1mm is exceeded, check that no foreign bodies or debris at the bottom of the blind tapped holes is keeping the surfaces apart and, if not, a workshop overhaul should be carried out to bring the apparatus to as new condition. Periodically, when the lampglass is removed, the opportunity should be taken to remove the reflector, check the lampholder connections for signs of over-heating and similarly check the control gear.
- 9 The terminal chamber should be opened periodically and checked for moisture and dirt ingress. The cable connections should be checked for tightness. The gasket* should be checked for cracks or lack of elasticity, and if necessary, replaced. (It may well be practical to also replace the gasket* on each occasion if this is at a 3-year interval). Torque 6Nm.
- 10 If painting operations have taken place around the luminaire, ensure that coatings have not entered the flameproof path or been deposited on the lampglass. If they have, dismantle and clean carefully.
- 11 Check that mountings are secure.
- 12 Cover the bolt heads with silicone grease to prevent corrosion and accumulation of dirt in the screw threads.
- 13 Clean the lampglass.
- 14 If there is suspicion that the luminaire has suffered mechanical damage, a stringent workshop check should be made.

Important: *Where spares are needed, these must be replaced with manufacturer parts. No*

modifications should be made without the knowledge and approval of the manufacturer.
* EPDM Gasket not to be fitted below -20°C.

3.9 Electrical Fault Finding and Replacement

The supply must be isolated before opening the luminaire. With Mercury and GLS lamps the faults are simple, loose or broken connections, unserviceable lamps or open circuit control gear. Control gear will not normally go open circuit unless it has overheated first and the signs of this are obvious, being severe discoloration of the paint on the gear and cracks in any exposed insulation. Similarly, a bad contact at the lamp cap will usually result in signs of overheating. Any fault finding must be done by a competent electrician and, if carried out with the luminaire in place, under a permit to work. With HPS and MBI lamps the ignitor can become faulty. If the lamp is fitted, the choke has continuity and the connections are good and correct, they should produce an 'attempt to start' effect and a buzzing sound from the ignitor. It will be unusual to have no other parts available to perform a substitution fault finding routine and this is the normal procedure. Before re-assembling, all connections should be checked and any damaged cable replaced. The ignition connection to the lampholder is sleeved with H.T. sleeving and this must be kept in place.

4.0 Fuse Ratings

The fuse ratings for HID lamp circuits need to take account of three components of circuit current. Current inrush to PFC capacitors which can be up to 25x the rated capacitor current and last 1-2 milliseconds; lamp starting current including steady capacitor current which together may decline from up to 200% of normal at 10 seconds after switch-on to normal after 4 minutes; rectification effects

caused by asymmetrical cathode heating for a few seconds after starting, this effect is random and very variable.

With the availability of MCB's with a wide range of characteristics, the individual engineer can make a better judgement of what is required. Use MCB's suitable for inrush currents to reduce ratings. The normal capacitor current will probably be the determining factor, 0.076A per μF at 240V, 50Hz (adjust for other volts by multiplication, x 6/5 for 60Hz). For HBC fuses use 1.5 x normal capacitor current. For GLS inrush use 6x rated current. All calculations must satisfy wiring regulations.

Note: Starting and running currents for 240V, 50Hz are as indicated in

TABLE 1. A conventional matrix for HBC fuses is shown in TABLE 2.

5.0 Disposal of Material

The unit is mostly made from incombustible materials. The capacitor is of the dry film type and does not contain PCB's. The control gear contains plastic parts and polyester resin. The ignitor contains electronic components and synthetic resins. All electrical components may give off noxious fumes if incinerated. Take care to render these fumes harmless or avoid inhalation. Any local regulations concerning disposal must be complied with. Any disposal must satisfy the requirements of the WEEE directive [2002/96/EC] and therefore must not be treated as commercial waste. The unit is

mainly made from incombustible materials. The control gear contains plastic, resin and electronic components. All electrical components may give off noxious fumes if incinerated.

5.1 Lamps

Incandescent lamps and discharge lamps in modest quantities are not "special waste". The outer envelope should be broken in a container to avoid possible injury by fragmentation. This applies to the UK, there may be other regulations on disposal operating in other countries.

Important: Do not incinerate lamps.

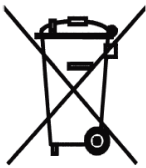

To comply with the Waste Electrical and Electronic Equipment directive 2002/96/EC the apparatus cannot be classified as commercial waste and as such must be disposed of or recycled in such a manner as to reduce the environmental impact.

Tables 0/1/2							
Table 0	Lamp Ranges and Temperature Ratings					Refer to Section :	1.0
Lamp	Wattage	Rated Supply	T Class	T amb °C -50°C to	Dust Rating °C	Cable Rating °C	Cable Rise °C
GLS	150	110 to 250V	T4	60	130	90	20
GLS	150	"	T4	50	110	70	20
GLS	200	"	T3	60	145	90	20
GLS	200	110 to 250V	T4	50	125	70	20
GLS	300	110 to 240V	T4	40	130	70	30
SON/E	70	(210 to 254V, 50Hz	T4	50	105	70	20
SON/E	70	220 to 270V, 60Hz)	T4	60	125	85	20
SON/E	70	"	T5	40	95	70	20
SON/E	100	"	T4	60	125	80	20
SON/E	100	"	T4	40	105	70	20
SON/E	150	"	T3	55	140	80	30
SON/E	150	"	T4	40	125	70	30
SON/E	250	"	T3	40	150	80	40
SON/R	250	"	T3	40	130	80	40
MBF/U	80	"	T4	60	125	80	20
MBF/U	80	"	T4	50	115	70	20
MBF/U	125	"	T3	50	135	80	30
MBF/U	125	"	T4	40	125	70	30
MBF/U	250	"	T3	40	175	80	40
MBI	70	"	T4	50	105	70	20
MBI	70	"	T4	60	125	85	20



MBI	70	"	T5	40	95	70	20
MBI	100	"	T4	60	125	80	20
MBI	100	"	T4	40	105	70	20
MBI	150	"	T4	40	140	70	30
MBI	150	"	T3	55	125	80	30
MBI	250	"	T3	40	140	80	40
MBTF	160	(210 to 254V, 50Hz	T3	40	135	70	30
MBTF	160	220 to 270V, 60Hz)	T3	50	145	80	30
QL	55	120V, 220-240V	T5	55	75	70	25
QL	85	120V, 220-240V	T5	55	75	70	25
QL	165	120V, 220-240V	T5	40	80	70	30

Alternatively the ambient temperature range may be -20°C or -45°C to above.

Table 1	Starting and Running Currents		Refer to Section :	4.0
Lamp	Start A	Run A	Capacitance µF	Circuit Power (W)
70W HPS	0.72	0.40	10	80
100W HPS	1.00	0.56	10	114
150W HPS	1.35	0.75	20	168
250W HPS	2.34	1.30	30	286
80W MBFU	0.70	0.39	10	90
125W MBFU	1.13	0.63	10	136
250W MBFU	2.80	1.40	20	280
70W MBI	0.72	0.40	10	80
100W MBI	1.00	0.56	10	114
150W MBI	1.60	0.80	20	175
250W MBI	2.70	1.35	30	280

Note: Minimum power factor correction: 0.85.

Table 2	Fuse Ratings					Refer to Section :	4.0
Lamp	Number of Lamps						
	1	2	3	4	5	6	
70W HPS	4A	4A	4A	6A	6A	10A	
100W HPS	4A	4A	6A	10A	10A	10A	
150W HPS	4A	6A	10A	10A	16A	16A	
250W HPS	10A	16A	16A	20A	20A	20A	
80W MBFU	4A	4A	4A	4A	6A	6A	
125W MBFU	4A	4A	6A	10A	10A	10A	
250W MBFU	10A	16A	16A	20A	20A	20A	
70W MBI	4A	4A	4A	6A	6A	10A	
100W MBI	4A	4A	6A	10A	10A	10A	
150W MBI	4A	6A	10A	10A	16A	16A	
250W MBI	10A	16A	16A	20A	20A	20A	

	<p>PO Box 5575 Glasgow, G52 9AP Scotland</p> 	
	<p>Telephone: +44 (0)141 882 5555 Fax: +44 (0)141 883 3704 Email: info@chalmit.com Web: www.chalmit.com</p>	<p>Registered No: 669157 Registered Office: Mitre House, 160 Aldersgate Street London, EC1A 4DD</p>