

INSTALLATION, OPERATION AND MAINTENANCE INSTRUCTIONS Acclaim III - Recessed Fluorescent Luminaires CSA

Standard and Emergency Models

Important: The emergency luminaire has automatic test functions and the emergency lamp will operate on mains after delays up to one minute. Please read these instructions carefully before installing or maintaining this equipment. Good electrical practices should be followed at all times and this data should be used as a guide only.

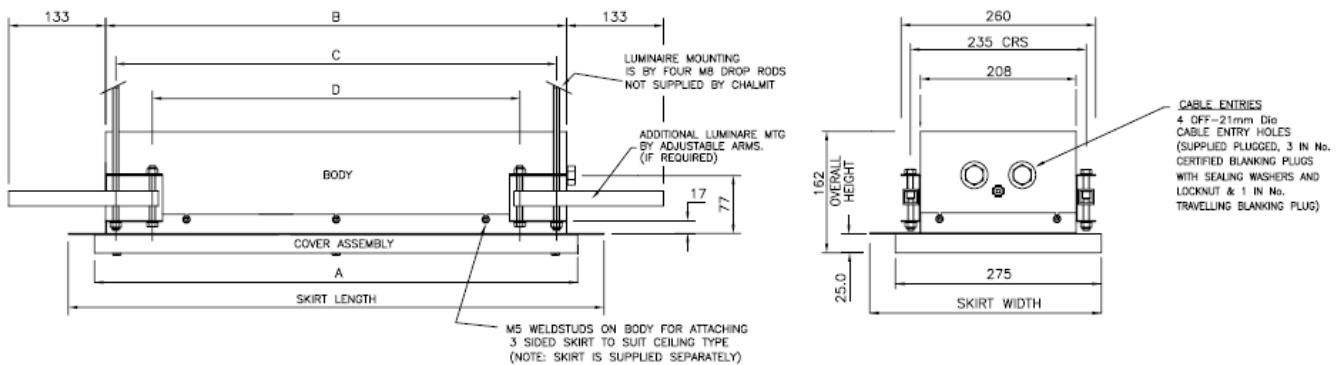

MODEL	A	B	C	D	SKIRT LENGTH	SKIRT WIDTH	CUT OUT SIZES
2X18W	750	720	700	600	820	309	800(L) x M300 TILE WIDTH
2X36W	1365	1335	1315	1215	1435	309	1415(L) x M300 TILE WIDTH



0.0 Specification

Type(s) of protection	Ex e Increased safety, Ex q Powder filling, Ex m Encapsulation, Ex d Flameproof
Protection standards	E79-0, E79-1, E79-5, E79- 7, E79-18.
Installation	CEC 22.1, NEC 505, IEC 60079-14
Area Classification	Class 1, Zone 1 Group II, Groups A, B, C, D.
Certificate	201067-1358946
Equipment coding	AEx eqm II T4 bi-pin lamps and AEx eqd IIC T4 mono-pin lamps with Fa6 caps to IEC 60081. Tamb -20/+45°C as an insulated recessed unit and Tamb 20/+55°C as a non-insulated recessed unit.
Ingress Protection	CSA TYPE/NEMA Enclosure 4. IP65

1.0 Introduction – Acclaim III CSA Model

The Acclaim III EM series is a recess-able luminaire for use with fluorescent lamps with the facility of an internal battery back up for emergency use. The Acclaim III models have Ex q control gear, electronic safety sensor and micro-processor controlled emergency functions. The luminaire can be constructed to interface with fire resistant ceiling systems to maintain a B15 SOLAS fire rating; care must be taken to maintain this classification. When insulated, refer to Chalmit for Tamb ratings, as it affects life and battery performance. Normal operation is mains supply two lamps on, switching to one lamp on battery back up and having local switching of the mains lamps, the emergency lamp only being energised on mains failure.

The luminaires are available in 2 x 18W, 1 x 36W and 2 x 36W sizes, and also in 2 x 18W and 2 x 36W sizes for emergency use.

Refer to the current catalogue for information on product references. The range is available for use with T8 bi-pin lamps and T8 mono-pin lamps with Fa6 caps to IEC81.

Note: *This range is available in a number of similar but distinctly different versions. Care must be taken to use the correct instructions and spares, if in doubt contact sales or product support.*

2.0 Storage

Luminaires are to be stored in cool dry conditions preventing ingress of moisture and condensation.

Any specific instructions concerning emergency luminaires must be complied with.

3.0 Installation and Safety

3.1 General

These instructions should be read fully and carefully before attempting to install the luminaire. For details of servicing operations, opening etc. see section 6.0.

Copies of these instructions should be held in a safe place for future reference. It is the responsibility of the installer to ensure that the apparatus selected is fit for its intended purpose and that the installation, operation and maintenance of the apparatus complies with applicable regulations, standards or codes of practice.

There are no health hazards associated with this product whilst in normal use, however, care should be exercised during the following operations.

Installation and cabling should be carried out in accordance with *CEC 22.1, NEC 505 or IEC 60079-14* or with a local hazardous area code of practice whichever is appropriate. Any specific installation instructions must be referred to. Disposal instructions should be complied with.

The luminaires should be considered Class 1 and effectively earthed.

The polycarbonate diffuser presents a potential source of ignition by **electrostatic electricity**. The diffuser should only be cleaned using a damp cloth. The luminaire should not be mounted very near to any probable location of fast moving stream of dry air, steam etc. which could generate a propagating brush static discharge.

Certification details on the rating plate must be verified against the application requirements before installation.

The information in this leaflet is correct at the time of publication. The company reserves the right to make specification changes as required without notice.

3.2 Tools

3mm and 4mm flat blade screwdriver and large crosshead screwdriver. Suitable spanners for installing cable glands. Pliers, knife, wire strippers/cutters.

3.3 Electrical Supplies

Luminaires are supplied with control gear suitable for the following rated supplies:

Emergency 110-120V or 220-254V ac +/-10% 50/60Hz +/- 5%

Non-emergency 220-254V ac +/-10% 50/60Hz +/- 5% and 220-300V dc +/-10%

Non-emergency 110-120V ac +/-10% 50/60Hz +/- 5% and 110-150V dc

The safety limit for surface temperature (T rating) is +/-10% on the rated voltage. Equipment should not be operated continuously at more than +10/-10% of the rated voltage of the control gear. The power factor correction gives a minimum of 0.95 lagging. The lamp supply is regulated therefore the change in light output over the supply range is substantially unchanged.

Warning: *Electronic control gear is assessed and/or tested for EMC requirements. This is based on the disposition of entry cables and, where appropriate, through wiring arrangements as supplied or specified. Users must take care not to introduce wiring into parts of the apparatus materially*

different to that which could be reasonably inferred from the disposition of fixed supply terminals and specified through wiring.

3.4 Lamps

The lamps used in the range can be T8 bi-pin fluorescent with G13 cap or T8 mono-pin fluorescent with Fa6 caps. Lamp caps are to IEC 60061, lamp dimensions and safety to IEC 61195 and lamp performance to IEC 60081. **Please note that this luminaire is suitable for IEC lamps only. Do not use American specification lamps.**

3.5 Mounting and Insulation

Luminaires should be installed where access for maintenance is practical and in accordance with lighting design information. Refer to the note in 3.1 concerning electrostatic charge.

When mounting of ceiling support channels, via side arms or adjustable side arms, they must be secured onto channels by fixing screws. When B15 fire rating is a requirement all conditions stated by the ceiling manufacturer and Chalmit must be met.

As an insulated recessed unit the Tamb rating is 45°C as a non-insulated unit in a plain recess the Tamb rating is 55°C. Therefore the usual mounting in a metal ceiling with 75 mm of insulation at 45°C is acceptable. If the temperature in an installation is continuously at the limiting level the duration will be reduced and the self-testing will be delayed.

3.6 Cabling and Cable Glands

The temperature conditions at the supply cable entry point are such that 70°C (ordinary PVC) cable can be used. Cable glands and sealing plugs must meet the requirements of CEC 22.1, NEC 505 or IEC 60079-0. The cable and gland assembly when installed must maintain a minimum IP54 rating.

Where the cable **is not reliably clamped** externally to the apparatus the cable gland must clamp the cable against a pull in Newtons of 20 x the cable OD in mm.

Four entries are provided. Three entries are fitted with suitably approved blanking plugs, the fourth entry with a transit plug. M20 x 1.5 entries are standard, other sizes are available on request. The standard entry configuration is with an earthed metal plate with tapped holes mounted in the body.

3.7 Electrical Connections and Testing

If work other than re-lamping is to be done on any luminaire already connected to the electrical system, the luminaire must be isolated from the system. Access for the cabling is via removal of front cover and lamp tray.

The front cover is secured using 6/10 off M6 captive screws, care to be taken as there is no suspension on this, and lampholder tray is secured by M5 screws and keyhole slots, with chain suspension allowing the tray to swing down, giving access to terminal blocks. Install the conductors in the appropriate terminals. Take care not to cut the conductor insulation excessively, 1mm of bare conductor outside the terminal throat is a maximum. Before re-fitting lampholder tray and front cover, the cores/cable should be neatly tucked away and a final check made on correct connections.

The through current rating is 16A. 4mm² terminals are standard (6mm² wiring can be used in the terminals in accordance with the luminaire certificate).

Screw type or screw-less “cage clamp” terminals are fitted in the range of luminaires. Mains terminal blocks are marked L N Earth.

Mains terminal blocks on the emergency luminaires are marked Lc Ls N Earth.

Luminaires can also be supplied with three phase wiring to special order. The marking is L1 L2 L3 (L s) N Earth. The emergency units can be connected as switched, un-switched or non-maintained units. The switching facility is to allow the luminaire to be switched off whilst still charging the battery. Where switching is required, the un-switched line (Lc) is connected to the continuous mains supply. A link is fitted during assembly between Lc and switched line (Ls); this is removed for the switch-able mode. If the link is removed and Ls not supplied, the unit will only operate on emergency.

If the emergency luminaire is on a three phase system the switched line can be on any phase, it does not need to be on the phase connected to the un-switched line.

If local emergency inhibition (see 4.3) is required the luminaire should be ordered with the connections for this feature built in. The emergency inhibition function is connected via terminals, which must be specified to be included when ordering. The inhibition terminals are marked Ext Sw 1 and 2, see wiring diagram.

The electrical wiring will consist of two connections to the control gear brought out to an extra terminal block at the mains supply terminals. The switch should be of 5 VA rating and, if in the hazardous area, Ex protected.

The switch must have contacts which will reliably conduct small currents (10 mA levels) at low (6V) voltage. For information on suitable surface mount switches refer to Chalmit sales department. Closed circuit is normal, off inhibits the emergency function. Up to ten luminaires and 500m of cable can be connected in parallel to one switch. *If the polarity is crossed the emergency function will work but can not be inhibited.*

If the inhibition is connected into a circuit with CEAG emergency luminaires having an inhibition connection the Acclaim must be connected as follows EXTSW1 should be connected to CEAG “2” EXTSW2 should be connected to CEAG “3”.

The looping terminals for this function are at the right hand end. As there are four entries, four core cable must be used for looping the inhibition terminals if the mains through wire connection is to also be used. If any other configuration is needed it must be specially ordered or the internal wiring pack changed on site.

The cabling is made off to the correct length in the normal manner. Care should be taken not to cut the insulation back too far. The maximum amount of insulation allowed beyond the throat of the terminal is 1mm. The normal method of insulation testing is to connect Live and Neutral together and test between this point and Earth to prevent the risk of damage to the electronic control gear. However, if this is not possible luminaires can be tested with an insulation tester that complies with IEC 364 with a maximum output current of 1mA and output voltage of 500V dc. The inhibition circuit can be tested at 500V dc whilst connected to the luminaire terminals. (Units damaged by incorrect insulation testing can be detected).

Before completing the wiring, ensure that all the connections are correctly introduced into place before reassembling the luminaire. Following cabling, lamps can be fitted. New lamps should be used.

4.0 Emergency Operation

4.1 General description of emergency unit and operation

The integrated unit consists of a mains supplied ballast for feeding the fluorescent lamps in normal situations, a battery pack, an emergency circuit that charges the battery and powers the lamp in an emergency situation, and a micro-controller based supervisory circuit that controls the charging, monitors the emergency functions and displays the results of self test and emergency unit status by means of a red and green LED.

The unit can be connected to an external switch that can inhibit the emergency functions when the mains power is on or off and restart the emergency functions with or without mains power being applied. The terminals for this feature must be specified when ordering. (See 3.7).

By switching the voltage on a connection Ls the lamps can be switched on and off without the emergency function being activated. The Ls connection is insulated from L and has a signal function only drawing a very small current.

The luminaire will go seamlessly into emergency mode at not less than 60% rated supply voltage and will remain in mains mode above 85% of rated supply voltage.

On restoration of the mains supply there will be a **60 sec delay** before the emergency lamp is restored to mains operation. This feature is not common on emergency luminaires and should be noted. The feature is provided to increase reliability when operating in bad supply conditions.

The charging function is monitored continuously, there is a check for over charging and no charging. In case of a control gear fault three red flashes, followed by a pause are displayed.

After a complete battery discharge, the unit will switch over to a low discharge current mode.

4.2 Self testing

An immediate full test of capacity can only be made by manually de-energising the installation and timing the discharge. The LED indication will show if the duration is less than 2.5 hours or 2 hours if the temperature during the test is very high or very low. $45^{\circ}\text{C} < T_{\text{amb}} < -5^{\circ}\text{C}$, with mains lamps operating normally prior to test). The control continuously monitors all charging functions.

The unit will self test for a short period every 13 days. The short self testing is for emergency function. The initial starting time for the self test routines is at a random point in the 13 day cycle, starting at the first mains energisation after the battery is connected or re-connected. During the 13 day self test the unit will test for function including lamp condition. The test will last 9 minutes with one lamp being energised at emergency level during the test period, the other lamp will remain on. If Ls is off, the short test is delayed until Ls is re-energised. The unit will perform a complete battery discharge every “3” months (102 days) and will check for minimum emergency duration as stated above. The start of the first complete battery discharge is at a random point between 0 and 102 days after applying mains voltage. The test will be repeated at fixed 102 day intervals. The unit will also complete a full self test after completing a commissioning cycle to full charge and after battery replacement. The full commissioning cycle takes about 50 hours.

The test will be delayed if the battery is not fully charged or the operating temperature at the time is too high to give a proper result or Ls is off. The test is also made after the initial installation and energisation and a full charge cycle completed. One lamp remains energised at normal mains output. The long test will also take place once the charge period is complete after a battery is changed or disconnected then re-connected.

The emergency lamp condition is monitored during every lamp start. If the lamp ignition is not correct the LED will display repeated red flashes. This will happen even if the lamp does ignite and run at the normal light level. If the self-test detects a failure it is indicated as follows. At the start of the automatic long test the emergency lamp will switch off for 9 mins so that it can cool down and make the starting test fully valid.

Refer to the Table 1 below.

Emergency lamp defective: continuous red flashing.

Battery defective or low capacity: two red flashes, followed by a pause.

Emergency unit defective: three red flashes followed by a pause.

If the charge condition is known, the unit will re-charge from empty to approximately 80% charge in 14 hours.

Afterwards a reduced current post charge will be applied to complete the charge. If the battery charge condition is unknown (e.g. first connection) a reduced charge is applied for 44 hours.

For battery temperatures below 10°C charge current is reduced and charge time increased.

The charging function is monitored continuously, there is a check for over charging and no charging. In case of a fault three red flashes, followed by a pause are displayed.

After a complete battery discharge, the unit will switch over to a low battery discharge mode which maintains the memory and monitoring function. The control contains dedicated features which prevent any unsafe condition arising if the micro-processor were to malfunction.

LED display

The status is displayed by means of red and green LED signals.

The green LED will flash slowly, if the batteries are being charged, and all emergency functions were found to be OK during the last self-test.

The green will be steady at full charge.

The red will flash if there is a fault or a warning.

Table 1: Monitoring function indication

GREEN	RED	MODE	REMARKS
Fast flash ½ sec on, ½ sec off		Charge C/10	
Slow flash 1 sec on, 1 sec off		Charge C/20	Charging currents at low temperatures reduced
Steady		Fully charged	
Fast Flashing alternate Red-Green	Fast flashing alternate Red-Green	Less than one ½ hour duration left during emergency operation. Also see 5.2.2	One lamp at emergency light level
	fast flashing	Emergency lamp near end of life	Both lamps on or off
	2 red flashes repeating	Battery faulty or battery not connected or low duration after long test	Minimum duration limit during long test not met
	3 red flashes repeating	Fault in electronics of power supply	
Slow flash or steady	Periodic short flash once per 4 secs	Mains on emergency inhibited	
None	None	Defective display	Lamps on
None	None	Mains off, battery discharged, or mains off inhibited or total unit defective	Lamps off

4.3 Inhibition (also see 3.7)

If local emergency inhibition is required the luminaire should be ordered with the connections for this feature built in. The electrical wiring will consist of two connections to the control gear brought out to an extra terminal block at the mains supply terminals. Closed circuit is normal, open inhibits the emergency function. Up to ten luminaires can be connected in parallel to one switch and using 500m of cable.

The inhibit as well as de-inhibit functions can start with normal mains power present as well as without mains power, the emergency light can be switched on while the whole power system is still dead. Inhibition is not possible with a completely discharged battery and no mains being present. The emergency function can be inhibited and de-inhibited whilst in emergency operation. Return to emergency operation is instant. The change to lamp off when put into inhibited mode may be delayed for up to 60 secs,

5.0 Commissioning (Refer to section 6.0 for access)

The units will only be fully operational and give completely correct indication after the completion of a full charge, self-test discharge and recharge cycle, approx. 100 hours. Once this is complete the unit will have its full operating parameters installed in the memory. Provided the battery is not disconnected indication will function correctly.

Non-emergency luminaires are energised after the lamps are fitted and the luminaire closed. Both lamps should light. Open the cover the lamps will go out.

5.1 Commissioning Emergency

5.2 Commissioning with no mains power available.

After inserting the lamps and closing the cover, the unit will go onto emergency mode until discharged if the initial battery voltage is high enough. (> 5.5V).

If the emergency inhibition switch is in the blocked condition the lamp will go on for 60 seconds unless there is not enough charge in the battery to sustain it for that time.

5.3 Commissioning with mains power available.

If a local light switch is connected put it on.

After inserting the lamps and closing the cover the unit will light on battery as above. At power up the mains lamp will light and emergency lamp will light fully after 60 secs. This feature is designed to increase reliability in very frequent mains on and off situations or irregular supply such as may occur during commissioning.

The initial charge will be indicated by a green flashing LED.

If an emergency blocking switch is present a short red flash every 4 sec will be displayed if the switch is in the blocked state.

If the battery charge condition is unknown (e.g. first connection) a reduced current charge is applied for 44 hours.

The long self test takes place after the initial installation and energisation has been made and a full charge cycle completed. The test will be delayed if the operating temperature at the time is too high to give a proper result or if Ls is off. One lamp remains energised at normal mains output. **See 4.2.** After the test the unit will fast charge to 80% then post charge to fully charged and the indication will then be steady green.

Until the full charge and test cycle has been completed the unit will indicate low battery on any emergency discharge.

5.4 Low Temperature Operation

At battery temperatures below 10°C charge current is reduced and charge time increased. This temperature is equivalent to the luminaire operating at -5°C with the lamps on or at +5°C with the lamps off.

Under operating conditions where the ambient temperature is below 0°C for long periods the luminaire should preferably be used in maintained mode so that the mains supplied lamps warm up the battery to a normal working temperature.

6.0 Servicing and Operation

The luminaire incorporates an electronic safety de-energiser for maximum reliability and utility of the emergency monitoring function. The electronic sensor is operated by the actuating plate on the cover. This provides for the safe opening and carrying out of re-lamping.

Safe servicing behind the gear tray requires the mains supply to be isolated, and battery connections must be treated with care, see 6.8.

6.1 Opening and Closing front cover

The front cover is secured using 6/10 off M6 captive screws, care to be taken as there is no suspension on this.

Safe servicing behind the gear tray requires the mains supply to be isolated, and battery connections must be treated with care, see 6.10.

6.2 Fitting lamps and Re-Lamping

IMPORTANT - If the luminaire is maintained with the power on, the lamps will go out when the cover is opened. If this does not happen there is a fault. Do not remove the lamps. The control gear will be damaged if the lamps are removed without being de-energised and there is an ignition risk. This could occur if the sensor arrangement is faulty or has been defeated. The luminaire must be de-energised the control gear checked and electronic sensor assembly must be replaced if faulty, see 6.9.

Lamps which are not operating or appear dim should be replaced as soon as practical. The control gear is designed to withstand end of life conditions of lamps. The emergency unit will indicate in advance that the lamp is approaching end of life. Always replace both lamps.

The bi-pin lamps are fitted in lampholders with a rotating section. The lamp must be pushed firmly down into the lampholder and rotated 90°. The contact is biased to remain in the 90° position. If the lamp does not rotate, check that it is completely positioned into the lampholder. The Fa6 cap lamps are fitted in the spring loaded lamp-holders which are pulled out to allow the introduction of the lamp. Before inserting bi-pin or mono-pin lamps ensure the lamp pins are not damaged or slack in the end cap.

6.3 Releasing the Reflector/Gear Tray

Loosen the four fixing screws retaining the reflector/gear tray far enough for it to slide over keyhole slots. The tray will hang on the retaining cords without stressing the wiring between body and tray. Replace in reverse order.

The lampholder assemblies can be removed from the gear tray, if necessary, by removing the fixing screw and pushing up the click finger at the end of the gear tray and pushing the lampholder assembly forward towards the centre of the tray.

Re-assembly is a reversal of the above, ensure the lampholder assembly fully clicks into place on the gear tray. Lampholder assemblies have the connecting receptacles and are specific to each model. If they are being replaced the correct spare assembly must be ordered.

6.4 Removal of Reflector/Gear Tray c/w Lampholder Assemblies

Release gear tray from body and hang on retaining cords, as explained above. Disconnect the cables from the gear tray to the mains terminal block, unhook retaining cord from gear tray and lift clear.

6.5 Servicing Behind the Gear Tray

The release of the gear tray exposes live mains terminals. Any work behind the gear tray requires that the supply is isolated to avoid ignition risk and damage to components.

6.6 Replacement of Ballast or Emergency Control

The ballast contains no replaceable parts. Should it be found necessary to replace the ballast, the following procedure should be adopted:

Ensure that the luminaire is isolated from the mains supply.

Remove gear tray from body and swing down as previously explained. Undo the battery plug on emergency luminaires.

Ballasts use 6mm tab connectors which are locked and are released when the black cover sleeve is pulled away axially. When replaced a 'click' will be heard as the lock locates. **On no account should the quick release connectors be replaced with proprietary items.**

Disconnect the leads to the ballast, note the connections. When removing the connections **always disconnect** the sensor and LED connections (LED1 LED2 PRPT1 and PROT2) **last** and reconnect them **first**. Remove the ballast retaining screws and remove ballast from tray.

Replacement of the units is in the reverse order. **The sensor is connected first and the battery last.** Check the connections carefully before re-energising. The lamp leads on the emergency are marked as pairs. Take care to connect correctly. The unit is **not** protected against reverse battery polarity. The yellow leads are the high voltage ones. Miss-connection of the units will be very likely to result in damage. **Care and checking during replacement can not be over emphasised.**

6.7 Replacement of sensor with or without LED assembly

It is very unlikely that this assembly will need replacement other than as a result of mechanical damage.

Isolate the mains. Disconnect the battery, disconnect the sensor and note the connections. Undo the two screws and replace the unit using the nuts from the old unit. Reconnect and carefully check the connections before re-energising.

6.8 Replacement of battery

The battery is accessed by releasing the gear tray fixing screws sliding the tray and hinging it down.

The battery is connected to the control using a plug and socket arrangement. The battery load is disconnected by the electronic sensor device. The screws holding the battery pack are loosened and the battery pack slid axially one way then the other in order to release. The battery pack is not intended to be opened and is replaced as a unit. The battery is potentially incandive but is protected during removal by the IP30 construction which covers live parts. The battery assembly must be protected from damage and water ingress then **removed from any potentially hazardous area as soon as practical.**

The replacement battery is slid axially one way then the other in order to insert then the screws are tightened. The socket is then inserted. The luminaire must not be operated without the battery connected. If the battery is removed and not replaced the control gear supply must be disconnect at the mains terminal block and secured.

6.9 Checking of Battery separately

The easiest way of checking the battery is in a known serviceable luminaire against the rated duration.

If the battery is to be checked separately, it should be charged using a **constant current charger** at 200/400mA for 30/15 hours for the 4Ah (18W) or 350/700mA for 30/15 hours for the 7Ah (36W). Discharge measurement is not easy as the current is proportional to the voltage for resistance loads, so it has to be averaged. Discharge the battery at 1 to 2A and multiply current by time. Do not discharge below 1 volt per cell, that is 5V. The capacity should be 70% or more of normal.

7.0 Routine Maintenance

Visual tests and checks should be carried out at intervals described by the appropriate regulations.

Check that the lamps are working or appear badly aged. Blackening at the lamp ends is a good indication of length of use.

Check for mechanical damage/corrosion.

Check for loose connections including earthing.

Check for undue accumulations of dust or dirt.

Verification of tightness of fixing, glands, blanking plugs etc.

Check for unauthorised modifications.

Check condition of enclosure gasket and fastenings.

Check for any accumulation of moisture.

Periodic inspection of the enclosure seal should be carried out to ensure that the seal is sound. The seal can be replaced and, if necessary, secured in position by the application of a small amount of silicone RTV adhesive.

If the luminaire has been subject to abnormal conditions, for example, severe mechanical impact or chemical spillage, it must be de-energised until it has been inspected by an authorised and competent person. If in doubt, the unit should be returned to Chalmit for examination and, if necessary, replacement.

7.1 Fault finding

In general, installations of luminaires have a number of units on site. Once apparently faulty components are in the workshop fault finding is done by substituting known healthy components. Except for checking continuity to the supply and ballast input connections there is little that can be done to fault find using instruments. Live testing and use of meters on high frequency units in a workshop will gain little information and may damage healthy components. Take great care in connecting and disconnecting see 6.7. Use a charged battery wait for 60 seconds for units to respond.

7.1.1 Non emergency

The lamps will run until one fails to strike. Fit new lamps. If the result is not satisfactory, check continuity to the ballast. If still no result, check the continuity to lampholders after disconnecting leads from ballast. If no fault found replace ballast. If still no result, disconnect the connection to the sensor. If the lamps light this would indicate a faulty sensor, see 6.9, but as this is most unlikely, check all connections before replacing.

7.1.2 Emergency

Check for operation of the LED. **If the LED is red** refer to the table which shows the fault diagnostics. If the unit does not work on the mains with Ls energised carry out the checks in 7.1.1. If mains operation can not be restored replace the control unit.

A service operation, that is opening and closing the cover, will often re-set faulty lamp indication but the indication will reoccur so the lamp must be changed.

If fault finding is done on an emergency unit before a full commissioning cycle has been completed care must be taken to ensure that the faults are real. Check that the inhibition circuit is complete, see 3.7 and 4.3.

With faults occurring later the first action is always to fit new lamps. If the unit does not work on mains with both lamps, 60 sec delay on emergency lamp, and Ls is powered there is a fault. The second action is to fit a new battery *with some charge in it*. These actions can be done with the luminaire installed. If the result appears positive leave the luminaire in place for a charging period. Work after this would be expected to be done by removing the gear tray to the workshop. It will be easier to work using a complete luminaire and put the gear tray into it. When working this way do not lie the tray in the diffuser as the sensor may be activated inadvertently.

In general, installations of luminaires have a number of units on site and fault finding is done by substituting known healthy components. If changing batteries always use one with some charge, A voltage of 6.0V will be enough to avoid problems. See 6.11.

Except for checking continuity to the supply and ballast input connections there is little that can be done to fault find using instruments. Care is needed in the workshop as miss-connection will damage units. Always check connections carefully. Live testing and use of meters on high frequency units in a workshop will gain little information and may damage healthy components.

The usual first service operation with emergency units which appear to work normally on mains but not on emergency is to energise for a few minutes before checking emergency operation. If no result, check that the inhibit connection is closed circuit. If the unit works on emergency let it discharge fully. The unit should then be energised for 60 mins and the discharge re-checked.

If the unit runs for a few minutes it is charging. If not, change the battery and repeat the full discharge and short charge test. If okay, give the unit a full 48 hour charge and check the duration. If there are still fault indications replace the control unit.

7.2 Cleaning

The diffuser should not be polished or wiped with a dry cloth as a risk of ignition due to electrostatic discharge may result. Cleaning of the diffuser with any chemical or hydrocarbon solvent based cleaner may result in severe damage.

8.0 Fuse and MCB Ratings

It is recommended that for selection of MCB's users should consult the MCB manufacturer as this unit contains electronic control gear. MCB ratings can vary depending on the manufacturer and type and the size of the installation, i.e. impedance of conductors. The electronic control gear has an inrush current of 30A for 500µs on 230V, emergency and non-emergency, 45A for 350µs on 110V, non-emergency, and 35A for 250µs on 110V, emergency. These figures are for low resistance connections with short cables and low impedance supplies.

9.0 Disposal of Material

General

The unit is made from combustible materials. The control gear contains plastic parts and electronic components. All electrical components and the body parts may give off noxious fumes if incinerated. Take care to render these fumes harmless or avoid inhalation. Any local regulations concerning disposal must be complied with. Any disposal must satisfy the requirements of the WEEE directive [2002/96/EC] and therefore must not be treated as commercial waste. The unit is mainly made from incombustible materials. The control gear contains plastic, resin and electronic components. All electrical components may give off noxious fumes if incinerated.

9.1 Lamps

Fluorescent lamps in modest quantities are not "special waste". They should be broken up in a container to avoid injury, avoid inhaling dust.

Important: *Do not incinerate lamps.*

9.2 Battery Disposal

Nickel cadmium batteries are defined as 'controlled waste' under the hazardous waste regulations and the person disposing needs to observe a 'duty of care'.

Batteries can be returned to the manufacturers for recycling. They must be stored and transported safely and any necessary pollution control forms completed prior to transportation. Take care to fully discharge batteries before transporting, or otherwise ensure that there can be no release of stored energy in transit. For further details refer to our Technical Department.



To comply with the Waste Electrical and Electronic Equipment directive 2002/96/EC the apparatus cannot be classified as commercial waste and as such must be disposed of or recycled in such a manner as to reduce the environmental impact.

Table 2 Nominal Lamp Power and Supply Current

Supply Voltage	Lamps	Power W	Current A
230V, 50/60Hz	2 x 18W / 1 x 36W	35	0.17
	2 x 18W Emergency	40	0.19
	2 x 36W	70	0.32
	2 x 36W Emergency	77	0.36
110V, 50/60Hz	2 x 18W / 1 x 36W	35	0.34
	2 x 18W Emergency	40	0.38
	2 x 36W	70	0.65
	2 x 36W Emergency	77	0.73

Power Factor >0.98. Power is constant over voltage range.

- Tamb Storage** -40°C to +80°C
- EMC** EN 50081-2 (emission)
EN 50082-2 (immunity)
EN 61000-3-2 (harmonics generated)
- Over voltage** 400V ac for 1 min
EN 61000-4-5 > 4kV
- Batteries** 6V 7Ah NiCd (36W)
6V 4Ah NiCd (18W)
- Emergency Duration** 3 hours to EN 60598 2-22 @ Tamb 25° C
(The standard requires the 3 hour duration after 4 years of operation)
4 hour duration units are special
- Emergency Output** 1200mm lamp 25% of normal single lamp output
600mm lamp 30% of normal single lamp output
4 hour duration units are special and give 80% of these values.

Chalmit Lighting is a leading supplier of Hazardous Area and Marine Lighting products

	<p align="center">CHALMIT LIGHTING PO Box 5575 Glasgow, G52 9AP Scotland</p>	
<p>Telephone: +44 (0) 141 882 5555 Fax: +44 (0) 141 883 3704 Email: info@chalmit.com Web: www.chalmit.com</p>	<p>Registered No: 669157 Registered Office: Mitre House, 160 Aldersgate Street, London, EC1A 4DD</p>	

For technical support, please contact: techsupport@chalmit.com

Note: Chalmit Lighting reserves the right to amend characteristics of our products and all data is for guidance only.