

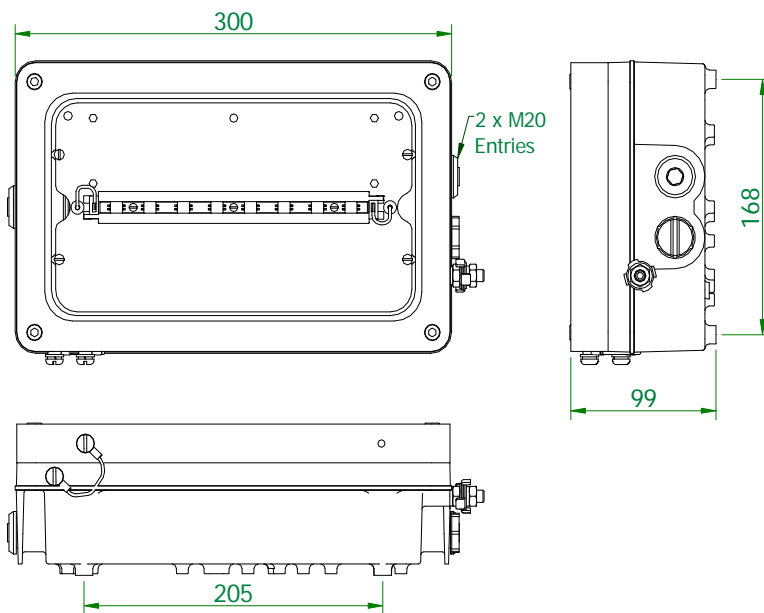

# INSTALLATION, OPERATION AND MAINTENANCE INSTRUCTIONS

## NexLED - Bulkhead Luminaires

### ATEX & IECEx

**Important:** Please read these instructions carefully before installing or maintaining this equipment. Good electrical practices should be followed at all times and this data should be used as a guide only.



Protection Standards	EN/IEC 60079-0, 60079-7, 60079-18, 61241-1
ATEX Classification	Group II Category 2 G D
Area of application	Zone 1 and Zone 21 areas to EN/IEC 60079-10-1 and 60079-10-2.
Installation	EN60079-14
Certificate	EC Type Examination Certificate Baseefa04ATEX0245 IECEx Certificate of Conformity IECEx BAS 09.0062
Equipment Coding	 II 2GD Ex e mb IIC T4 Gb -45°C ≤ Ta ≤ +55°C Ex tb IIIC T95°C Db IP66
Ingress Protection	IP66 and IP67 to BS EN 60529
Laser safety class	Class 1 LED product
CE Mark	The CE marking of this product applies to "The Electrical Equipment (Safety) Regulations 2006", "The Electromagnetic Compatibility Regulations 2004", the "Waste Electrical and Electronic Equipment Regulations 2006" and the "Equipment and Protective Systems intended for use in Explosive Atmospheres Regulations 1996". [This legislation is the equivalent in UK law of EC directives 2006/95/EC, 2004/108/EC and 2002/96/EC respectively].

Declaration of compliance with standards: The Equipment is declared to meet the provisions of the ATEX directive (94/9/EC) by reason of the EC Type Examination and compliance with the Essential Health and Safety Requirements.

I MacLeod Technical Manager

**SPECIAL CONDITIONS FOR SAFE USE**

None

**1.0 Introduction**

The Chalmit NexLED brings to hazardous areas the very latest in lighting technology. It is a compact light source that uses ultra bright light emitting diodes to provide light from mains power. The LEDs are maintenance free and can last up to 80000 hours or more. They are housed in an impact and corrosion resistant marine grade aluminium enclosure with a toughened glass lens. The control gear is electronic with regulated lamp output. The LEDs work equally well at very low temperatures as they do at high and produce a product with very low overall power consumption. The LEDs also emit no ultra-violet light and no forward heat.

The product is available with 2 or 8 lamps and an accessory kit is available for exit signs.

Led	2 x 1W	8 x 1W
Voltage range AC	110 - 254V	
Frequency range Hz	50/60/0Hz	
Power Watts 220-254V	7W	14W
Current Amps 220-254V	49mA	0.80A
Power Watts 110-130V	7W	14W
Current Amps 110-130V	80mA	120mA

The safety limit for surface temperature (T rating) is +/-10% on the rated voltage. Equipment should not be operated continuously at more than +10/-10% of the rated voltage of the control gear.

- Power Factor** 0.85 minimum
- EMC** EN 61547 EN 55015
- Over voltage** 400V ac for 1 min
- Looping** The looping current rating is 16A. 4mm<sup>2</sup> terminals are standard (6mm<sup>2</sup> wiring can be used in the terminals in accordance with the luminaire certificate).
- Tamb Storage** -40°C to +50°C
- Storage** Luminaires are to be stored in cool dry conditions preventing ingress of moisture and condensation.
- LED** The LED used in the Nexled is the latest technology and is a class 1 LED product.
- Fuse and MCB Ratings** Current consumption of an 8 lamp unit is 80mA and for a 2 lamp unit 49mA. It is recommended that for selection of MCB's users should consult the MCB manufacturer. MCB ratings can vary depending on the manufacturer and type and the size of the installation, i.e. impedance of conductors, however type 'C' breakers are usually suitable. The electronic control gear has an inrush current of 12A for less than 1ms on 230V. These figures are worst case with low resistance connections with short cables and low impedance supplies.

**2.0 Storage**

Luminaires and control gear boxes are to be stored in cool dry conditions preventing ingress of moisture and condensation. Any specific instructions concerning emergency luminaires must be complied with.

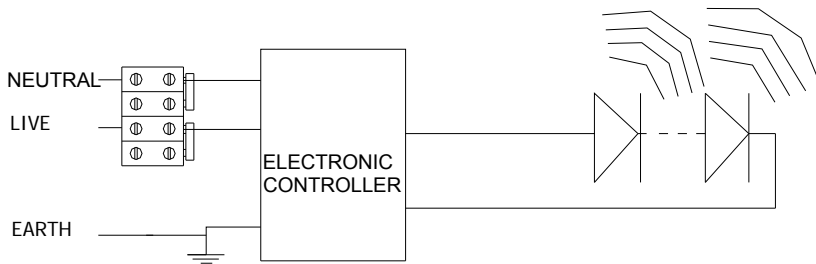

WIRING DIAGRAM FOR NON-EMERGENCY LED DRIVER

### 3.0 Installation and Safety

#### 3.1 General

There are no health hazards associated with this product whilst in normal use. However, care should be exercised during the following operations. Installation should be carried out in accordance with *EN/IEC 60079-14* or the local hazardous area code of practice, whichever is appropriate, and fitting of specified insulating material to be adhered to where a specific fire resistance rating is required. In the UK the requirements of the 'Health and Safety at Work Act' must be met. Handling and electrical work associated with this product to be in accordance with the 'Manual Handling Operations Regulations' and 'Electricity at Work Regulations, 1989'. Your attention is drawn to the paragraphs (i) 'Electrical Supplies', (ii) 'Electrical Fault Finding and Replacement' and (iii) 'Inspection and Maintenance'. The luminaires are class 1 and should be effectively earthed. Certification details on the rating plate must be verified against the application requirements before installation. The information in this leaflet is correct at the time of publication. The company reserves the right to make

specification changes as required.

#### 3.1.1 Use in Combustible Dust Atmospheres

Where the equipment is used in ignitable dust atmospheres reference must be made to the selection and installation standards in order that the equipment is used correctly. In particular this applies to the derating of surface temperature for use where dust clouds may be present. Dust layers should not be allowed to accumulate on the surface and good housekeeping is required for safe operation. Dust in layers has the potential to form ignitable clouds and to burn at lower temperatures. Refer to *EN/IEC 60079-10-2*.

#### 3.1.2 Hybrid Mixtures – Gas and Dust

Where hybrid mixtures exist as defined in *EN 1127* as a potentially explosive atmosphere, consideration should be given to verifying that the maximum surface temperature of the luminaire is below the ignition temperature of the hybrid mixture.

#### 3.2 Tools

No 1/2 Philips/Pozidriv/T20 Torx screwdrivers  
3mm and 5mm flat blade screwdriver

Spanners for installing cable glands. Pliers, knife, wire strippers/cutters.

#### 3.3 Electrical Supplies

The standard unit is rated for a nominal 110V-254V AC 50Hz or 60Hz. A maximum voltage variation of +6%/-6% on the nominal is expected. (The safety limit for T rating is +10%). Equipment must not be operated outside of the rated voltage of the control gear. The lamp supply is regulated therefore the light output over the supply range is constant.

#### 3.4 LED Array & Driver

This product is fitted with LED lamps that can last in excess of 80000 hours. Therefore in many applications replacement of the LED array will be unnecessary. If replacement is required ensure mains supplies are isolated before commencing work. Remove the front cover and then remove the LED array mounting plate by disconnecting the cables. In the event that the LED Driver needs replacement first disconnect the cables then remove the Torx head screws. Assembly is the reverse of disassembly making sure that the polarity is correct that the earths are connected and also ensuring the gasket/glass mating surfaces are clean and cables are not trapped.

### 3.5 Mounting

Luminaires should be installed where access for maintenance is practical and in accordance with any lighting design information provided for the installation. Mounting is by 4 holes in the base of the body casting external to the gasket. These should be secured with lock washers or self-locking nuts and bolts and are accessed by removing the front cover. Any mounting attitude may be used.

### 3.6 Cabling and Cable Glands

#### 3.6.1 Cables

The maximum conductor size is 6mm<sup>2</sup>. Internal earth point is provided next to the main terminal block. 300/500V cable ratings are adequate and no special internal construction is necessary. The standard looping cable size is up to 6mm<sup>2</sup>. The selection of cable size must be suitable for the fuse rating. Terminals are supplied with suitability for looping. Where looping is used the maximum current is 16A. Terminals are accessed by removing the front cover and LED array. Maximum cable temperature rise is 20°C above ambient.

#### 3.6.2 Cable Glands

The installer and user must take responsibility for the selection of cables, cable glands and seals. Three tapped cable entries are provided, two with a plug and seal suitable for permanent use, the other with a travelling plug not suitable for use in service. Sealing plugs are similarly rated and a tool must be used for their removal. Cable

entries are M20x1.5. Cable glands and sealing plugs must have ATEX approval or be certified to EN60079-0. For installation outside the EU suitable cable glands in accordance with IEC 60079-0 will meet the technical requirements.

The cable and gland assembly when installed must maintain a minimum of IP54 rating. The cable glands must be suitable for the application. Where brass cable glands are used in a corrosive environment, cadmium or nickel plating should be used.

### 4.0 Inspection and maintenance

Visual inspection should be carried out at a minimum of 12 monthly intervals and more frequently if conditions are severe; refer to EN/IEC 60079-17.

### 4.1 Electrical fault finding and replacement

Any fault finding must be done by a competent electrician with the luminaire isolated and, if carried out with the luminaire in place, under a permit to work. Fault finding is by substitution with known good components.

### 5.0 Routine Maintenance

Visual tests and checks should be carried out at intervals described by the appropriate regulations, EN/IEC 60079-17, and should include the following:

Check that the LEDs are working.

Check for mechanical damage/corrosion.

Check for loose connections including earthing.

Check for undue accumulations of dust or dirt.

Verification of tightness of fixing, glands, blanking plugs etc.

Check for unauthorised modifications.

Check condition of enclosure gasket and fastenings.

Check for any accumulation of moisture.

Periodic inspection of the enclosure seal should be carried out to ensure that the seal is sound.

If the luminaire has been subject to abnormal conditions, for example, severe mechanical impact or chemical spillage, it must be de-energised until it has been inspected by an authorised and competent person. If in doubt, the unit should be returned to Chalmit for examination and, if necessary, replacement.

Before re-assembling, all connections should be checked and any damaged cable replaced.

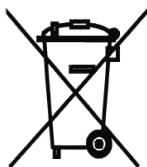

### 6.0 Disposal of Material

The unit is mainly made from incombustible materials. The control gear contains plastic resin and electronic components. All electrical components may give off noxious fumes if incinerated. Take care to render these fumes harmless or avoid inhalation. Any local regulations concerning disposal must be complied with. Any disposal must satisfy the requirements of the [WEEE directive \[2002/96/EC\]](#) and therefore must not be treated as commercial waste.



To comply with the Waste Electrical and Electronic Equipment directive 2002/96/EC the apparatus cannot be classified as commercial waste and as such must be disposed of or recycled in such a manner as to reduce the environmental impact.

Chalmit Lighting is a leading supplier of Hazardous Area and Marine Lighting products

	<p align="center"><b>CHALMIT LIGHTING</b> PO Box 5575 Glasgow, G52 9AP Scotland</p>	
<p>Telephone: +44 (0) 141 882 5555 Fax: +44 (0) 141 883 3704 Email: <a href="mailto:info@chalmit.com">info@chalmit.com</a> Web: <a href="http://www.chalmit.com">www.chalmit.com</a></p>	<p>Registered No: 669157 Registered Office: Mitre House, 160 Aldersgate Street, London, EC1A 4DD</p>	

For technical support, please contact: [techsupport@chalmit.com](mailto:techsupport@chalmit.com)

Note: Chalmit Lighting reserves the right to amend characteristics of our products and all data is for guidance only.