

# INSTALLATION, OPERATION AND MAINTENANCE INSTRUCTIONS

## Sterling II - Fluorescent Luminaires

### Industrial

**Important:** Please read these instructions carefully before installing or maintaining this equipment. Good electrical practices should be followed at all times and this data should be used as a guide only.

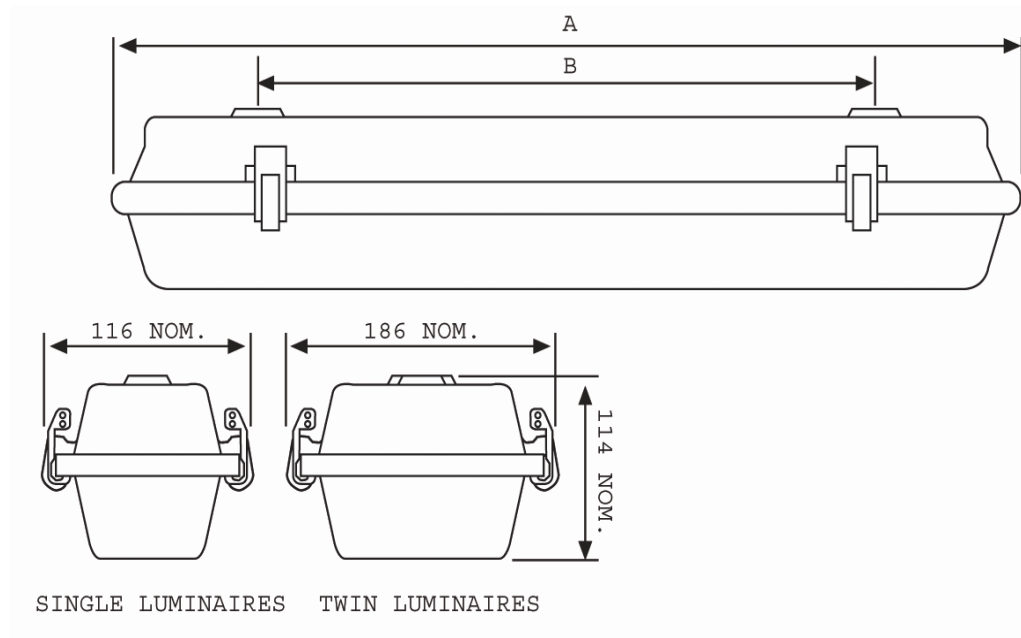

DIMENSIONS	A	B
18W	702mm	500mm
36W	1312mm	800mm
58W	1612mm	1100mm



## 0.0 Specification

Area Classification	Non-Hazardous (Industrial)
Standard	BS EN 60598-1 : 1997
Ingress Protection	IP65 to BS EN 60529

CE Mark



The CE marking of this product applies to "The Electrical Equipment (Safety) Regulations 1994", "The Electromagnetic Compatibility Regulations 1992", the "Waste Electrical and Electronic Equipment Regulations 2006" and the "Equipment and Protective Systems intended for use in Explosive Atmospheres Regulations 1996". [This legislation is the equivalent in UK law of EC directives 2006/95/EC, 2004/108/EC and 2002/96/EC respectively].

## 1.0 Introduction – Sterling II Safe Area Fluorescent Luminaire

The Sterling Safe Area fluorescent luminaires are surface mounted or suspended, utilising the 2 holes on base of body. They are mainly used in harsh environments, and are constructed using a corrosion resistant glass reinforced polyester body or a stainless steel body attached to an injection moulded polycarbonate diffuser by self-retaining stainless steel toggle clips. The control gear and lampholders are mounted on a removable tray, which for maintenance has hanging straps.

## 2.0 Storage

Luminaires and control gear boxes are to be stored in cool dry conditions preventing ingress of moisture and condensation.

Any specific instructions concerning emergency luminaires must be complied with.

## 3.0 Installation and Safety

### 3.1 General

There are no health hazards associated with this product whilst in normal use. However, care should be exercised during the following operations. Installation should be carried out in accordance with the local area code of practice, whichever is appropriate.

In the UK the requirements of the 'Health and Safety at Work Act' must be met.

Handling and electrical work associated with this product to be in accordance with the '*Manual Handling Operations Regulations*' and '*Electricity at Work Regulations, 1989*'. Your attention is drawn to the paragraphs (i) 'Electrical Supplies', (ii) 'Electrical Fault Finding and Replacement' and (iii) 'Inspection and Maintenance'. The luminaires are Class 1 and should be effectively earthed.

The information in this leaflet is correct at the time of publication. The company reserves the right to make specification changes as required.

### 3.2 Tools

Screwdriver flat blade 12mm and 3mm. Suitable spanners for installing glands.

Pliers, knife, wire strippers/cutters.

### 3.3 Electrical Supplies

The supply voltage and frequency should be specified when ordering. A maximum voltage variation of +6%/-6% on the nominal is expected, however the ballast is designed to accept tolerances of up to +/-10%. Luminaires should not be operated continuously at more than +/-10% of the rated supply voltage of the control gear or tapping. **Care is needed connecting to the nominal 230V UK public supply.** The user must determine the actual underlying site supply and purchase or adjust accordingly. Normally luminaires for 230V and 240V, 50Hz rating are supplied with a tap.

If the equipment is located in high or low voltage sections of the system, an appropriate voltage tap should be selected, but care must be taken to log or mark the equipment so that the tapping is re-set if the equipment is re-located. If in doubt, tapings should be set on the high side.

### 3.4 Lamps

Lamps are bi-pin fluorescent tubes having the following ratings, 18W, 36W, 58W (T8) 26mm diameter tubes.

### 3.5 Mounting

Luminaires should be installed where access for maintenance is practical and in accordance with any lighting design information provided for the installation.

On mounting the luminaire by using the 6mm  $\varnothing$  holes, it is the responsibility of the user to ensure that an adequate seal is made to maintain the desired IP rating with a minimum of IP54. Washers are provided. Other mountings are available on request.

### 3.6 Cable Connection

#### 3.6.1 Cables

The temperature conditions of the supply cable entry point are such that 70°C (ordinary PVC) cable can be used in most luminaire models. On models where there is no fixed through wiring supplied by Chalmit but where there is a looping facility on the gear tray, any supply wiring passing through the body must either have a rating of 130°C or have sleeving fitted which has a 130°C rating. 300/500 volts cable ratings are adequate and no special internal construction is necessary. Where MCB's are used, the type with the higher short time tripping current ratio used for motor starting and lighting should be specified. The standard maximum looping size is 2.5mm<sup>2</sup> with options of 4mm<sup>2</sup> through wiring. An internal earth tag can be fitted to the cable gland.

#### 3.6.2 Cable Glands

Cable glands when installed should maintain the minimum IP65 rating of the enclosure. The cable gland should adequately secure the cable in the unit. Sealing plugs for unused entries should be similarly rated and fitted. Dependant on the model either 2 or 4 off 21mm diameter holes is provided. One transit plug is fitted all other entries are permanently plugged. It is the responsibility of the user to ensure that an adequate seal between the gland body and the apparatus is maintained. Tapped entries are available on the stainless steel bodies.

### 3.7 Cabling

Access for cabling is via diffuser cover, care is to be taken as there is no suspension of diffuser cover. The diffuser clips are undone and the diffuser laid aside. The gear tray is dropped down after rotating the turnbuckles or sliding the screws in the keyholes. The tray can be removed by undoing the spring clips on the suspension cables. The cable glands should be fitted with suitable washers to maintain the desired IP rating. Any earth tag connections should be fitted. The connecting terminals are identified and the conductors should be bared back so that they make full contact in the terminals, but the bare conductor should not be more than 1mm beyond the terminal. Unused terminal screws should be tightened. The cores must be identified by polarity and connected in accordance with the terminal markings. Before re-fitting the cover, a final check on the correctness of connections should be made.

Where switched operation is required on the emergency, remove the link and connect line and switched line separately.

#### 3.7.1 Fitting Lamps

Before opening the diffuser cover ensure that the luminaire is isolated from mains supply. Access for re-lamping is via diffuser cover, care is to be taken as there is no suspension of diffuser cover. Make sure that the correct lamp is selected. The lampholders are tombstone type, place the lamp in the lampholder and rotate 90° in lampholder. When inserting new lamps ensure the pins and lampholder connection is centralised. Replace diffuser cover and snap clips into place.

The emergency unit has no battery isolating arrangement, so if the lamp is replaced with the battery charged, take care **not** to touch the lamp cap or pins when removing or refitting the lamp.

### 3.8 Inspection and Maintenance

#### 3.8.1 Routine Examination

The luminaire must be de-energised before opening. Individual organisations will have their own procedures. What follows are guidelines based on our experience:

- 1 Ensure lamps are lit when energised by mains supply.
- 2 Visually check diffuser cover for damage, this should only be cleaned using a damp cloth to avoid static, and only use recommended detergents for polycarbonate. If the polycarbonate is discoloured or damaged, a new diffuser cover must be fitted.

- 3 When de-energised and left to cool, there should be no significant sign of internal moisture. If there are any signs of water ingress, the luminaire should be opened up, dried and any likely ingress points eliminated by re-gasketing or other replacements.
- 4 Check cable gland for tightness and nip up if required.
- 5 Check any external and internal earths.
- 6 Check all terminations are firmly screwed down, tighten if necessary.
- 7 Check clips visually for any damage, and replace if necessary.
- 8 If it has been suspected that the luminaire has suffered mechanical damage, a stringent workshop check on all components should be made. All components can be removed from the luminaire for inspection.

### 3.9 Electrical Fault Finding and Replacement

The supply must be isolated before opening the luminaire.

Any live fault finding must be done by a competent electrician and, if carried out with the luminaire in place, under a permit to work.

As the control gear is copper and iron, the fitting can be tested for continuity of connections.

If lamps go out repeatedly, and replacement lamps do not work or expected life is reduced, the control gear should be returned for replacement/testing.

On re-assembly, all faulty/damaged wiring should be replaced and connections checked. The electronic starter will cut out if lamps are defective.

#### 3.9.1 Battery Check and Replacement

The battery is contained in a tube which is sealed. The battery is detached at the plug and socket. Remove the two clamps to release the battery. Re-assembly is in reverse order.

**Important:** *Take care not to short the leads together as this can cause a fire.*

The emergency duration is 3 hours for all wattages. This will gradually degrade. The battery must be replaced when the duration is not acceptable.

If the electronic unit is healthy, the fuse is intact and the lamp sound, there should always be a little duration which will reoccur after a short period of recharging. The unit should be checked by a substitution.

Take care to fully discharge batteries before transporting, or otherwise ensure that there can be no release of stored energy in transit.

### 4.0 Disposal of Material

The unit is made from combustible materials. The capacitor is of the dry film type and does not contain PCB's. The control gear contains plastic parts and polyester resin. The ignitor contains electronic components and synthetic resins. All electrical components and the body parts may give off noxious fumes if incinerated. Take care to render these fumes harmless or avoid inhalation. Any local regulations concerning disposal must be complied with. Any disposal must satisfy the requirements of the WEEE directive [2002/96/EC] and therefore must not be treated as commercial waste. The unit is mainly made from incombustible materials. The control gear contains plastic, resin and electronic components. All electrical components may give off noxious fumes if incinerated.

#### 4.1 Lamps

Fluorescent lamps in modest quantities are not "special waste". They should be broken up in a container to avoid injury. Avoid inhaling dust.

**Important:** *Do not incinerate lamps.*

#### 4.2 Battery Disposal

Nickel cadmium batteries are defined as 'controlled waste' under the hazardous waste regulations and disposer needs to observe a 'duty of care'.

Batteries can be returned to the manufacturers for re-cycling. They must be stored and transported safely and any necessary pollution control forms completed prior to transportation. Take care to fully discharge batteries before transporting or otherwise ensure that there can be no release of stored energy in transit. For further details refer to Technical Department.

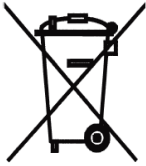

To comply with the Waste Electrical and Electronic Equipment directive 2002/96/EC the apparatus cannot be classified as commercial waste and as such must be disposed of or recycled in such a manner as to reduce the environmental impact.

**5.0 MCB Ratings**

MCB's allow the use of reduced cable sizes for the supply. The capacitance current is 0.076A per  $\mu\text{F}$  at 240V, 50Hz; this may be multiplied by 25 for 250 microseconds for calculation purposes.

**6.0 Emergency Self Test or Battery Monitoring Versions**

This version is capable of testing the performance of the emergency luminaire in accordance with BS5266-1: 2005 and IEC 62034.

Automatic Self Test

Commissioning Test - Connection of the mains supply will initiate commissioning where the battery will remain on charge for an uninterrupted 24 hours. An interruption of the mains supply will reset the counter to zero. After 24 hours the luminaire will be put into a duration test for the rated period, immediately followed by another 24 hour charge period.

If the mains supply is to be interrupted for more than 7 days, then the battery **MUST** be disconnected.

Functional Test - A 30 second functional test is carried out at 30 day intervals. This test can also be initiated manually by switching the permanent supply OFF/ON twice within 5 seconds.

Duration Test - A full rated duration test is carried out automatically at yearly intervals. Start times of the tests are set automatically to ensure random testing of the units.

LED Indicator - A bi-colour LED indicates the status of the module as follows:

Green	10 Second Blink	Normal standby mode
	Slow Flashing	Commissioning mode or Duration Test in Progress
	Fast Flash	Functional Test in Progress
Red	Slow Flash	Charging or Battery Fault
	Fast Flash	Lamp Fault

Slow Flash = 0.5Hz and Fast Flash = 2.5Hz

Audible Alarm - An audible alarm will sound if a fault is found during test and will continue to give 3 beeps every 35 minutes until the fault is rectified and the unit is reset.

User Reset Facility - A recorded fault condition may be cleared by switching either the permanent or switched supply OFF/ON twice within 5 seconds. A Functional Test is then carried out automatically to verify correct system operation.



Chalmit Lighting is a leading supplier of Hazardous Area and Marine Lighting products

	<b>CHALMIT LIGHTING</b> PO Box 5575 Glasgow, G52 9AP Scotland	
Telephone: +44 (0) 141 882 5555 Fax: +44 (0) 141 883 3704 Email: <a href="mailto:info@chalmit.com">info@chalmit.com</a> Web: <a href="http://www.chalmit.com">www.chalmit.com</a>	Registered No: 669157 Registered Office: Mitre House, 160 Aldersgate Street, London, EC1A 4DD	

For technical support, please contact: [techsupport@chalmit.com](mailto:techsupport@chalmit.com)

Note: Chalmit Lighting reserves the right to amend characteristics of our products and all data is for guidance only.