

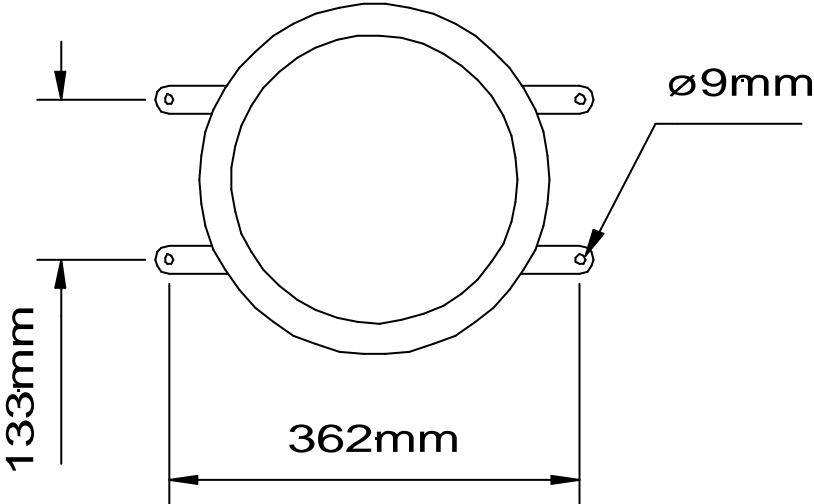

INSTALLATION, OPERATION AND MAINTENANCE INSTRUCTIONS

489 EPDM Bulkhead Luminaire

Important : Please read these instructions carefully before installing or maintaining this equipment. Good electrical practices should be followed at all times and this data should be used as a guide only.

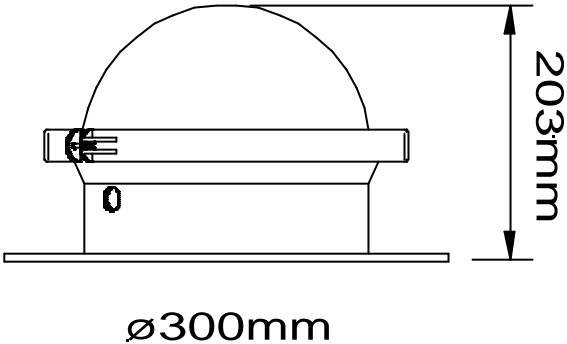

0.0 Specification

Type Of Protection	N/A	
Area Classification	Non-Hazardous	
Standard	BS EN 60598/01	
Certificate	N/A	
Material	Body	EPDM Rubber
	Cover	Injection Moulded Polycarbonate
Temperature Rating	(T amb) 35°C ceiling mounted, 40°C wall mounted to -40°C (HPS/Tungsten Halogen), -20°C (MBI/MBF), -10°C fluorescent	
Ingress Protection	IP65 to BS EN 60529	

CE Mark

 The CE marking of this product applies to "The Electrical Equipment (Safety) Regulations 1994", "The Electromagnetic Compatibility Regulations 1992", the "Waste Electrical and Electronic Equipment Regulations 2006" and the "Equipment and Protective Systems intended for use in Explosive Atmospheres Regulations 1996". [This legislation is the equivalent in UK law of EC directives 73/23EEC, 89/336/EEC and 2002/96/EC respectively].

1.0 Introduction - 489 Bulkhead

The 489 range is made with EPDM rubber body and polycarbonate cover. The 489H luminaire for portable applications is class II, the other luminaires are class I and must be effectively earthed. The units suitable for GLS lamps can use lamps up to 200W rating with a maximum current of 5A. The fixed luminaires have aluminium mounting brackets as standard, stainless steel can be supplied as an option. Blue and yellow domes are available for Heli-deck marking purposes.

Note : *Lamp ranges are as outlined in TABLE 0.*

2.0 General

Installation should be made in accordance with a code of practice where appropriate. In the UK, the requirements of the 'Health and Safety at Work Act' must be met. Lamps must be disposed of in a safe manner. The luminaires are (except for the 489H) Class I and should be effectively earthed. Some of the luminaires are heavy and suitable handling equipment must be provided.

Important : *For luminaires with electronic ballasts, the ballast must be disconnected before any High Voltage ("Megger") test is made.*

2.1 Electrical Supplies

The supply voltage and frequency should be specified when ordering. A maximum voltage variation +/- 6% on the nominal is expected. There have been some recent changes in voltage settings and tolerance for nominal supplies in the UK and Europe and these need to be taken into account. The specification for tappings on the control gear or lamps should be such that the supply does not exceed 106% of the nominal control gear setting or lamp voltage for other than abnormal conditions. In some cases, the luminaires have multi-tapped control gear which can be set to a range of 50 and 60Hz voltages. The tappings are shown on the control gear. If the equipment is located in high or low voltage sections of the system, an appropriate voltage tap should be selected, but care must be taken to log or mark the equipment so that the tapping is re-set if the equipment is re-located. If in doubt, tappings should be set on a high side as this will increase lamp life. All HPS circuits use SIP (superimposed pulse) ignitors.

This means that there are only two connections to the choke making the tap selection obvious. Where shore or construction site supplies are used, which are different to the service supplies, the tappings should be re-set. If not, advice on the effect of these temporary supplies should be sought from the Chalmit Technical Department.

2.2 Lamps

The high pressure sodium and mercury lamps are of the standardised type and there is no preference in make or colour. The luminaires using the PLC 13W lamp with electronic ballasts use the four pin type of lamp.

Care is needed to fit the correct lamp in order to obtain the design photometric performance. HPS lamp should be replaced shortly after they do not light. The indication of the end of life for HPS lamps is cycling where the lamp goes out then re-lights after a minute or so. The luminaires are now being fitted with anti-cycling ignitors giving a total of about 80 seconds of ignition during any switching on cycle, to protect against damage by end of life conditions. If discharge lamps are burned continuously, they should be switched off occasionally to allow lamps to fail to re-ignite, rather than possibly become diodes with possible detrimental effects on control gear. The above information was current at the time of printing. The development of lamps and control gear is on-going and detailed advice on lamp performance can be obtained from the lamp supplier or from Chalmit. HPS circuits should not be energised without a lamp fitted. HPS lamps with internal ignitors must not be used.

2.3 Mounting

Luminaires should be installed where access for maintenance is practical and in accordance with any lighting design information provided for the installation.

2.4 Cables

Temperature conditions of the supply cable are such that 70°C (ordinary PVC) can be used for single entry models. The standard cable section is 2.5mm² max. All models are suitable for 300/500V cable. If the model with looping facilities has been ordered and PVC cable is used, insulating sleeving should be added where the through cable is adjacent to the choke.

2.4.1 Cabling and Fitting Lamps

Access for fitting the lamp is by removing the front cover. The front cover is released by undoing the screw on the clamping band, when the band is replaced it should only be tightened to the stop. Lamps must be of the correct type and screwed or placed firmly into the lamp holder. To gain access to the cabling, the reflector is removed. In the case of fixed luminaires where glands are supplied, the cables should be suitable for making an IP seal in the gland. Where metal cable glands or plastic cable glands are used with the body having the internal frame to support the choke, a large washer should be placed on the outside under the cable gland to prevent the glands from being drawn into the rubber. Where portable luminaires are used, the cable should be of a flexible type with a minimum rating of 85°C (CSP/ERR) or similar.

Before cabling, any voltage tap re-selection should be made. The conductor ends should be prepared so that the conductors are properly gripped and the bare part of the conductor should not extend to more than 1mm beyond the throat. The connection should be made in accordance with the polarity marking. Any used terminal screws should be fully tightened. Before replacing the cover, a final check of the connections should be made.

3.0 Inspection and Maintenance

Routine inspection should be carried out at a minimum of 2 years interval and more frequently if conditions are severe. The time between lamps changes could be very infrequent and this is too long a period without inspection.

3.1 Routine Examination

The equipment must be de-energised and isolated before maintenance. Individual organisations will have their own procedures. What follows are guidelines based on Chalmit's experience :

- 1 Ensure the lamp is lit when energised and that the lampglass is not damaged. Check for superficial damage to the enclosure.

- 2 When de-energised and left to cool, there should be no significant sign of internal moisture. If there are signs of water ingress, the luminaire should be opened up, dried out, and any likely ingress points eliminated.
- 3 Check the cable gland for tightness and nip up if necessary. Check supply cables for damage.
- 4 Clean the lampglass.
- 5 Every three years, or more frequently, depending on experience, the control gear internal connections should be checked for tightness and any sign of corrosion or overheating. Any suspect components should be replaced.

3.2 Electrical Fault Finding and Replacement

With mercury vapour lamps the faults are simple, namely loose or broken connections, unserviceable lamps or open circuit control gear. Control gear will not normally go open circuit unless it has first overheated; the signs of this are obvious, being severe discoloration of the paint on the gear and cracks in any exposed insulation. Similarly, bad contact at the lamp cap will usually result in discoloration as a sign of overheating. Any fault finding must be done by a competent electrician and, if carried out with the luminaire in place, under a permit to work. With HPS lamps, the ignitor can become faulty. If the lamp is fitted, the choke has continuity and the connections are good and correct, they should produce an attempt to start the lamp and a buzzing sound from the ignitor. It will be unusual to have no other parts available to perform a substitution fault finding routine and this is the normal procedure. Before re-assembling, all connections should be checked and any damaged cable replaced. The ignition connection to the lampholder is sleeved with HT sleeving and this must be kept in place.

3.3 Overhaul

All the spares required are available. Please state the model number lamp and reflector details when ordering. The reflectors vary from between the various models.

4.0 Fuse Ratings

The fuse ratings for HID lamp circuits need to take account of three components of circuit current. Current inrush to PFC capacitors which can be up to 25 x the rated capacitor current and last 1-2 milliseconds; lamp starting current including steady capacitor current which together may decline from up to 200% of normal at 10 seconds after switch-on to normal after 4 minutes; rectification effects caused by asymmetrical cathode emission for a few seconds after starting, this effect is random and very variable. With the availability of MCB's with a wide range of characteristics, the individual engineer can make a better judgement of what is required.

The normal capacitor current will probably be the determining factor 0.076A per μF at 240V, 50Hz (adjust for other voltages by multiplication, x 6/5 for 60Hz). For HBC fuses use 1.5 x normal capacitor current.

Tungsten Halogen lamps have high inrush currents of 10 x the nominal current.

All calculations must satisfy wiring regulations.

Note : *Starting and running currents for 240V, 50Hz are as indicated in TABLE 1.
A conventional matrix for HBC fuses for HPS is outlined in TABLE 2.*

5.0 Disposal of Material

The capacitor is of a dry film type and does not contain PCB's. The control gear contains electronic components and synthetic resins. All the electrical components and the body and polycarbonate cover will also give off noxious fumes if incinerated, so care must be taken to render any fumes harmless and avoid inhalation. Any local regulations concerning disposal must be complied with. Any disposal must satisfy the requirements of the WEEE directive [2002/96/EC] and therefore must not be treated as commercial waste. The unit is mainly made from incombustible materials. The control gear contains plastic, resin and electronic components. All electrical components may give off noxious fumes if incinerated.

5.1 Lamps

Incandescent lamps, fluorescent lamps and discharge lamps in modest quantities are not "special waste". The outer envelope should be broken in the container to avoid injury.

This applies to the UK, there may be other regulations on disposal operating in other countries.

Important : *Do not incinerate lamps.*



To comply with the Waste Electrical and Electronic Equipment directive 2002/96/EC the apparatus cannot be classified as commercial waste and as such must be disposed of or recycled in such a manner as to reduce the environmental impact.

0.0 Tables 0/1/2

Table 0 Lamp Ranges

Refer to Section : 1.0

Cat. No.	Lamps	Lamp Holder	Weight kg	Voltage
489I/22	22W Fluor.	G10q	3.5	240V
489I/200/GL	200W GLS Max.	ES	3.2	25, 50, 110, 200, 220, 240V
489I/50/MV	50W MBFU	ES	4.6	220, 240V
489I/80/MV	80W MBFU	ES	4.6	220, 240V
489I/50/HS	50W SON	ES	5.0	220, 240V
489I/70/HS	70W SON	ES	5.0	220, 240V
489H	200W GLS Max.	ES	3.2	25, 50, 110, 200, 220, 240V
489I/13/CF	13W PLC	G24q	3.5	24, 50, 100, 240V

Table 1 Starting and Running Currents

Refer to Section : 4.0

Lamp	Start A	Run A	Capacitance μ F	Circuit Power (W)
22W Fluor.	0.21	0.14	6	31
50W HPS	0.41	0.3	8	65
70W HPS	0.55	0.4	10	80
13W PLC	0.11	0.11	-	13.6

Table 2 Fuse Ratings

Refer to Section : 4.0

Lamp	Number of Lamps					
	1	2	3	4	5	6
70W HPS	4A	4A	4A	6A	6A	10A



80W MBF

4A

4A

4A

4A

6A

6A

Chalmit Lighting
PO Box 5575
Glasgow
G52 9AP
Scotland

Telephone : +44 (0) 141 882 5555
Fax : +44 (0) 141 883 3704
Email : info@chalmit.com
Web : www.chalmit.com

For technical support, please contact: techsupport@chalmit.com

Registered Office:

Mitre House,
160 Aldersgate Street,
London,
EC1A 4DD

Registered No: 669157

Note :

Chalmit Lighting reserve the right to amend characteristics of our products, and all data is for guidance only.



Chalmit Lighting is a leading supplier of Hazardous Area and Marine Lighting products.