

# INSTALLATION, OPERATION AND MAINTENANCE INSTRUCTIONS

## 800 Series Ex nR CSA

### Class 1, Zone 2 Floodlight

**Important :** Please read these instructions carefully before installing or maintaining this equipment. Good electrical practices should be followed at all times and this data should be used as a guide only.

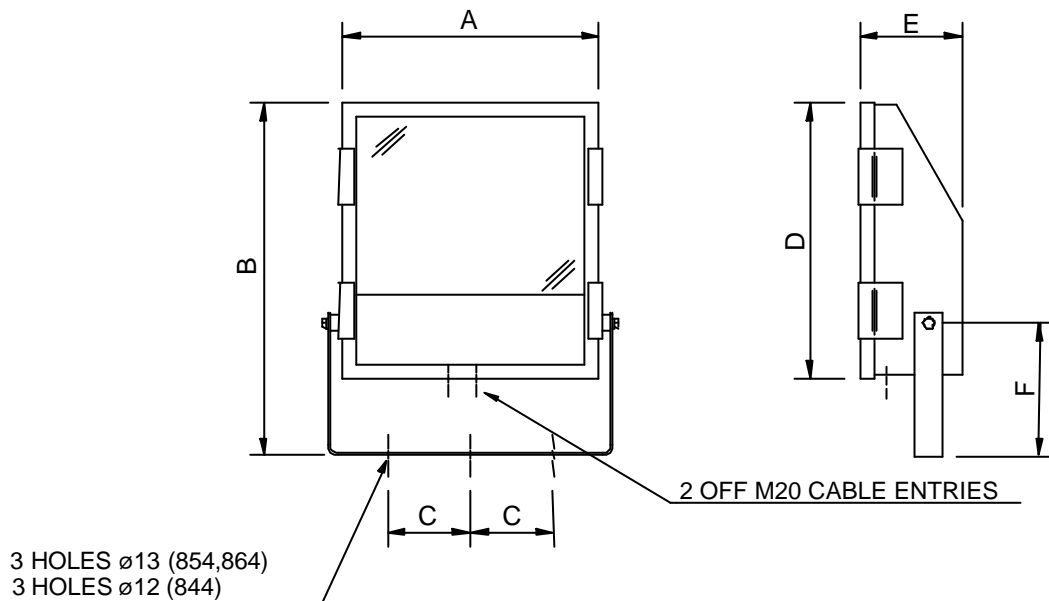

DIMENSIONS	844 70W	854 150/250/400W	864 250/400W
A	308	415	465
B	443	630	640
C	75	150	150
D	348	490	500
E	175	185	190
F	175	260	260

**Specification and ATEX Declaration**

Type(s) of Protection	Ex nR Class 1, Zone 2.
Standard	CAN/CSA E79-15-95
Area Classification	Class 1, Zone 2 Group II, Groups ABCD.
Installation	Canadian Electrical code C22.1
Equipment Coding	Ex nR II T3/T4 (Refer to Table 0 for Tamb)
Certificate	116028
Ingress Protection	CSA TYPE/NEMA Enclosure 4x. IP66 and IP67

<p>CE Mark</p> 	<p>The CE marking of this product applies to "The Electrical Equipment (Safety) Regulations 1994", "The Electromagnetic Compatibility Regulations 1992", the "Waste Electrical and Electronic Equipment Regulations 2006" and the "Equipment and Protective Systems intended for use in Explosive Atmospheres Regulations 1996". [This legislation is the equivalent in UK law of EC directives 73/23EEC, 89/336/EEC and 2002/96/EC respectively].</p>
--	--

**1.0 Introduction – 800 Ex nR Class 1, Zone 2 Floodlights**

**1.1 General**

The type of protection is Ex nR using a restricted breathing enclosure.

**Note :** *Lamp ranges, maximum ambient and surface temperature ratings are as indicated in TABLE 0.*

**1.2 Application**

The luminaire is designed to be safe in normal operation.  
 The luminaire should not be used in conditions where there are environmental, vibration or shock conditions above the normal for fixed installations.  
 The gaskets should not be exposed to hydrocarbons in liquid or high concentration vapour states.  
 The luminaire is suitable for applications where Class 1, Zone 2 is used. The application is for ignitable gas atmospheres.

**2.0 Storage**

Luminaires and control gearboxes are to be stored in cool dry conditions preventing ingress of moisture and condensation.

**3.0 Installation and Safety**

**3.1 General**

There are no health hazards associated with this product whilst in normal use. However, care should be exercised during the following operations. Installation should be carried out in accordance with the local hazardous area code of practice.  
 Your attention is drawn to the paragraphs (i) 'Electrical Supplies', (ii) 'Electrical Fault Finding and Replacement' and (iii) 'Inspection and Maintenance'. The luminaires are Class 1 and should be effectively earthed.  
 The luminaires are quite heavy and suitable means of handling on installation must be provided.  
 Certification details on the rating plate must be verified against the application requirements before installation. The information in this leaflet is correct at the time of publication. The company reserves the right to make specification changes as required. Refer to Canadian Electrical code C22.1 for specific installation requirements.

### 3.2 Tools

A piece of 6mm bar or a crosshead screwdriver blade to open the cover.  
19mm A/F spanner, 8mm A/F socket, 3mm and 5mm flat blade screwdriver.  
Pliers, knife, wire strippers/cutters.

### 3.3 Electrical Supplies

The supply voltage and frequency should be specified when ordering. A maximum voltage variation of +6%/-6% on the nominal is expected. (The safety limit for T rating is +10%). Luminaires should not be operated continuously at more than +6%/-10% of the rated supply voltage of the control gear or tapping. The user must determine the **actual** underlying site supply and purchase or adjust accordingly. In this case, the luminaires have multi-tapped control gear which can be set to the appropriate voltage. The tappings are shown on the control gear and the limits are shown on the rating plate. They are selected by the supply cable. If the equipment is located in high or low voltage sections of the system, an appropriate voltage tap should be selected, but care must be taken to log or mark the equipment so that the tapping is re-set if the equipment is re-located. If in doubt, tappings should be set on the high side. 10V Max. drop is desirable for HPS and advised for MBI. The light output will be reduced. The figures given are at the luminaire. Where MBI/Metal Halide lamps are used, the tapping must be set accurately for best performance.

Where shore or construction site supplies are used, which are different to the service supplies, the tappings should be re-set. If not, advice on the effect of these temporary supplies should be sought from the Technical Department. Where adverse system conditions occur, luminaires can be supplied without pfc. The circuit current will then be the lamp current, the circuit power does not change.

### 3.4 Lamps

*The luminaire may be supplied with either IEC or North American type gear. It is therefore imperative that the gear and lamp type be correctly and clearly specified when ordering to ensure that the characteristics of the gear match those of the desired lamp type.*

All the HPS lamps used in this range are of a standardised type and there is no preference between makes, or in the case of HPS, colour. The lamp cap varies with the lamp wattage; this must be clarified when ordering. The HPS lamps can be either European or US types; the 150W may be the low or high arc voltage types S55 and S56 respectively, this must be clarified when ordering. If mixed installations are used, care must be taken to ensure that the correct lamp is fitted on installation and replacement. The European 250W MBI lamp is the 3.A type. Where MBI lamps are specified care should be taken to ensure that the lamps are compatible with the gear as a pulse start ignitor may be fitted. HPS lamps substantially maintain their light output to the end of their electrical half-life, which can be up to 24,000 hours. However, lamp replacement at around 16,000 hours is desirable to avoid piecemeal replacement on a large scale. MBI lamps have a shorter life and higher lumen depreciation, **HPS and MBI lamps should be replaced shortly after they do not light**. One indication of the end of life for HPS lamps is 'cycling' where the lamp extinguishes then re-ignites after a minute or so interval. If discharge luminaires are burned continuously, they should be switched off occasionally to allow old lamps to fail to re-ignite, rather than possibly become diodes with detrimental effects on control gear.

The above information is current at the time of publication. The development of lamps and control gear is ongoing and detailed advice on lamp performance can be obtained from the Technical Department or the lamp supplier. Incandescent lamps and tungsten halogen must be selected for the supply voltage. Running at over the rated supply voltage will reduce life and at greater than +10% will compromise the T rating.

**Important :** *HPS and MBI circuits should not be energised without a lamp fitted. HPS & MBI lamps with internal ignitors must not be used.*

### 3.5 Mounting

Luminaires should be installed where access for maintenance is practical and in accordance with any lighting design information provided for the installation. This will usually consist of aiming points and aiming angles. The foot mounting or rear mounting arrangements should be secured with lock washers or self-locking nuts and bolts. The luminaire should be mounted with the lamp axis horizontal.

### 3.5.1 Weights and Windages

**Note :** *Weights and Windages for the various types are outlined in Table 5.*

## 3.6 Cabling and Cable Glands

### 3.6.1 Cables

The cable entry temperatures are given as the rise over the maximum rated ambient temperature. This allows the user to adjust the cable specification for actual site maximum temperature. The standard conductor section is 6mm<sup>2</sup> max. All models are suitable for looping. Standard 300/500V cable is suitable. The cable makeup must be suitable to ensure the obtaining of a restricted breathing enclosure when the cable gland assembly is fitted. Refer to Canadian Electrical Code C22.1 for guidance on cable suitability.

### 3.6.2 Cable Glands

Cable glands and sealing plugs, when installed, must maintain the restricted breathing enclosure. Refer to 3.8.2. Rubber sealing washers and steel compression washers are provided with the unit to seal between the gland body and the luminaire. The body torque value is 12Nm. The user must ensure that the assembly fulfils the above requirement. When new sealing arrangements are to be installed, users should check a sample for substantial air tightness before making a full installation. Entries suitable for M20 cable glands are standard. Entries suitable for M25 are available to special order.

### 3.6.3 Cable Gland Types

Refer to the cable gland manufacturers catalogue for further information with regard to compatibility with cable types. Refer to Chalmit for the assessment of other suitable types. These will be covered by a manufacturers declaration.

**Note :** *Cable gland types covered by the type examination are as indicated in TABLE 1.*

## 3.7 Cabling and Fitting Lamps

Access for cabling and fitting lamps is by removing the front cover. Before removing the cover on any occasion, check that the support chain is sound. The cover is released by undoing the six toggle clips using a screwdriver or a peg through the hole in the clip. The reflector is removed by releasing four screws. The baffle plate is removed by undoing the four M5 nuts on the underside. Reselect the voltage tapplings if necessary. Install the conductors in the appropriate terminals. Take care not to cut back the insulation excessively, 1mm bare conductor outside the terminal is a maximum. Any unused terminal should be fully tightened. When the cabling is complete, make a final tightness and connection check. Lamps must be of the correct type and firmly screwed into place. The cover is replaced and the toggle clips snapped back over.

## 3.8 Inspection and Maintenance

Visual inspection should be carried out at a minimum of 12 monthly intervals and more frequently if conditions are severe. The time between lamp changes could be very infrequent and this is too long a period without inspection.

### 3.8.1 Routine Examination

The equipment must be de-energised before opening. Individual organisations will have their own procedures. What follows are guidelines based on our experience:

- 1 Ensure the lamp is lit when energised and that the lampglass is not damaged.
- 2 When de-energised and left to cool, there should be no significant sign of internal moisture. If there are signs of water ingress, the luminaire should be opened up, dried out, and any likely ingress points eliminated by re-gasketing.
- 3 Check the cable gland for tightness and nip up if necessary.
- 4 Check all cover toggle clips for tightness. If they appear slack, re-set by reducing the angle of the long sides of the clips by bending until they require firm pressure to lock in place.
- 5 Clean the lampglass.
- 6 When relamping, check that the cover gasket has not softened or become excessively deformed, if in doubt replace ( See Section 4.0).

### 3.8.2 Restricted Breathing Properties

The test port provided in the enclosure housing (spare cable entry) is to be used for checking that the restricted breathing properties of the enclosure are retained in service. The restricted breathing properties shall be verified in accordance with the type test in clause 26.8 of IEC 60079-15. This opening must be closed or plugged during operation. The restricted breathing properties should be checked only when the surrounding atmosphere is known to be nonhazardous.

For all entry types, to maintain the restricted breathing properties a seal must be provided on all conduit or cable entries.

### 3.9 Electrical Fault Finding and Replacement

The supply must be isolated before opening the luminaire.

In most instances, the faults are simple, namely loose or broken connections, unserviceable lamps or open circuit control gear. Control gear will not normally go open circuit unless it has first over-heated; the signs of this are obvious, being severe discoloration of the paint on the gear and cracks in any exposed insulation. Similarly, a bad contact at the lamp cap will usually result in discoloration as a sign of overheating.

Any fault finding must be done by a competent electrician and, if carried out with the luminaire in place, under a permit to work. With HPS and MBI, the ignitor can become faulty. If the lamp is fitted, the choke has continuity and the connections are good and correct, they should produce an attempt to start effect in the lamp and a buzzing sound from the ignitor. It will be unusual to have no other parts available to perform a substitution fault finding routine and this is the normal procedure. Before re-assembling, all connections should be checked and any damaged cable replaced. The ignition connection to the lampholder is sleeved with H.T. sleeving and this must be kept in place.

#### 3.9.1 Thermal Protector

Thermal protectors are included in IEC gear equipped luminaires. If the lamp goes on and off over a timescale of several minutes, this could be the thermal protector operating. The causes are defective lamps/diode effects, gross over voltage or the choke beginning to fail and this should be investigated directly. Also see Section 3.4.

### 4.0 Overhaul

The unit is largely made of materials that are very corrosion resistant. This allows the unit to be completely stripped, cleaned, then re-built with new electrical parts as required. The internal wiring is 1.0mm<sup>2</sup> flexible, silicone rubber insulated. An H.T. sleeve is fitted to the ignitor cable. All the spares required are available. Please state the model number, lamp and reflector details.

The seal at the cover is between the glass and the body. The glass is retained in the cover frame by silicone R.T.V. adhesive.

If the cover gasket has deteriorated by softening or permanent set, a new cover assembly should be fitted, which can be obtained from Chalmit. As an alternative, a replacement gasket strip can be obtained from Chalmit. To fit this, care is needed, the old gasket should be removed and the remaining adhesive scraped off with a chisel type

blade. New strips are cut full length on the short sides and neatly butted on the long sides. The gasket is fixed in place and the butt joint sealed with silicone R.T.V. The cover assembly is left unclipped on top of a body with a sheet of thin polythene between it and the body to avoid adhesion. After a few hours the cover is removed and allowed to cure in free air for 24 hours. The cover should be tested on a test body for air tightness prior to being fitted to an overhauled unit.

## 5.0 Fuse Ratings

The fuse ratings for HID lamp circuits need to take account of three components of circuit current. Current inrush to PFC capacitors which can be up to 25 x the rated capacitor current and last 1-2 milliseconds; lamp starting current including steady capacitor current which together may decline from up to 200% of normal at 10 seconds after switch-on to normal after 4 minutes; rectification effects caused by asymmetrical cathode heating for a few seconds after starting, this effect is random and very variable. With the availability of MCB's with a wide range of characteristics, the individual engineer can make a better judgement of what is required. Use MCB's suitable for inrush currents to reduce ratings. The inrush current can be calculated where circuit conditions are known. The nominal capacitor current will probably be the determining factor, 0.076A per  $\mu\text{F}$  at 240V, 50Hz (adjust for other supply volts by multiplication, x 6/5 for 60Hz). For HBC fuses use 1.5 x normal capacitor current. All calculations must satisfy wiring regulations.

**Note :** *Starting and running currents for 240V, 50Hz are outlined in TABLE 2.  
Starting and running currents for 120V, 50Hz. are outlined in TABLE 3.  
A conventional matrix for HBC fuses is outlined in TABLE 4.*

## 6.0 Disposal of Material

The unit is mostly made from incombustible materials. The capacitor is of the dry film type and does not contain PCB's. The control gear contains plastic parts and polyester resin. The ignitor contains electronic components and synthetic resins. All electrical components and the body parts may give off noxious fumes if incinerated. Take care to render these fumes harmless or avoid inhalation. Any local regulations concerning disposal must be complied with. Any disposal must satisfy the requirements of the WEEE directive [2002/96/EC] and therefore must not be treated as commercial waste. The unit is mainly made from incombustible materials. The control gear contains plastic, resin and electronic components. All electrical components may give off noxious fumes if incinerated.

### 6.1 Lamps

Incandescent lamps and discharge lamps in modest quantities are not "special waste". The outer envelope should be broken in a container to avoid possible injury from fragmentation. Any local regulations concerning disposal must be complied with.

**Important :** *Do not incinerate lamps.*



To comply with the Waste Electrical and Electronic Equipment directive 2002/96/EC the apparatus cannot be classified as commercial waste and as such must be disposed of or recycled in such a manner as to reduce the environmental impact.

## 0.0 Tables 0/1/2/3/4/5

Table 0 Lamp Ranges and Temperature Ratings

Refer to Section : 1.1

Model	Wattage	Lamp	Min Ambient °C	Max Ambient °C	T Rating	Cable Temp Rise °C	Cable Rating °C	VA Rating (When fitted with Autotransformer)
844	70W	SON/T	-40	50	T3(150°C)	25	75	
				40			65	
854	100W	SON/T	-40	55	T4	20	75	
		SON/T	-40	50			70	
	150W	SON/T	-40	55	T3	25	75	
		MBI/T	-25				40	65
	250W	SON/T	-40	40	T4	25	65	
		MBI/T	-25					
854*	400W	SON/T	-40	40	T2	35	75	
		MBI/T	-25					
854	500W	T/Hal	-45	45	T3	40	85	
				60	T2		100	
864	250W	SON/T	-40	55	T3	30	85	
		MBI/T	-25					
	400W	MBI/T	-25	50	T3	30	80	
		SON/T	-40					
864**	150W	SON/T	-40	55	T3	20	75	500VA
	250W			50		30	95	
	400W							

**Note :** \* 400W 854 version is used in conjunction with an external gearbox.  
 \*\* These models have a 110V or a 120V supply.  
 SON lamps without PFC capacitors are suitable for a minimum ambient of -45°C.

Table 1 Cable Gland Types Refer to Section : 3.6.1

Gland Type	Make		
	Hawk Cable Glands	CMP Products	BICC Components
311	*		
321	*		
352	*		
353	*		
353T	*		
354	*		
VBL321	*		
VBL352	*		
VBL353	*		
VBL354	*		
A2F		*	*
E1FX		*	
E2FW		*	
E1FW		*	
A4e		*	
E1W			*
E1X			*
RTL			*

Table 2 Lamp, Starting and Running Currents (240V, 50Hz) Refer to Section : 5.0

Lamp	Lamp Current	Start Current	Running Current	PFC $\mu$ F	Circuit Power
70W	0.98	0.6	0.45	10	76
100W	1.2	1.0	0.56	10	114
150W	1.8	1.2	0.75	20	168
250W	3.0	2.65	1.35	30	282
400W	4.6	4.0	2.2	40	445

Table 3 Lamp, Starting and Running Currents (120V, 50Hz) Refer to Section : 5.0

Lamp	Lamp A	Start A	Running A	PFC $\mu$ F	Circuit Power
150W	1.8	2.4	1.5	20	170
250W	3.0	5.3	2.7	30	290
400W	4.6	8.0	4.4	40	450

**Note :** Minimum power factor correction: 0.85

Table 4 Fuse Ratings

Refer to Section : 5.0

Lamp Wattage	Number of Lamps					
	1	2	3	4	5	6
70W	4A	6A	10A	10A	16A	16A
100W	4A	6A	10A	10A	16A	16A
150W	4A	6A	10A	10A	16A	16A
250W	10A	16A	16A	20A	20A	20A
400W	16A	20A	20A	25A	25A	32A

Table 5 Weights and Windages

Refer to Section : 3.5.1

	Type					
	844/70	854/100	854/150	854/250	864/250	864/400
<b>Weight</b>	12.0kg	16.5kg	17.0kg	18.0kg	18.0kg	18.5kg
<b>Windage</b>	0.11m <sup>2</sup>	0.20m <sup>2</sup>	0.20m <sup>2</sup>	0.20m <sup>2</sup>	0.22m <sup>2</sup>	0.22m <sup>2</sup>

---

Chalmit Lighting  
PO Box 5575  
Glasgow  
G52 9AP  
Scotland

Telephone : +44 (0) 141 882 5555  
Fax : +44 (0) 141 883 3704  
Email : [info@chalmit.com](mailto:info@chalmit.com)  
Web : [www.chalmit.com](http://www.chalmit.com)

For technical support, please contact: [techsupport@chalmit.com](mailto:techsupport@chalmit.com)

**Registered Office:**

Mitre House,  
160 Aldersgate Street,  
London,  
EC1A 4DD

Registered No: 669157

**Note :**

Chalmit Lighting reserve the right to amend characteristics of our products, and all data is for guidance only.

---



Chalmit Lighting is a leading supplier of Hazardous Area and Marine Lighting products.