

---

# INSTALLATION, OPERATION AND MAINTENANCE INSTRUCTIONS

## Maxinex Floodlight IECEx

**Important :** Please read these instructions carefully before installing or maintaining this equipment. Good electrical practices should be followed at all times and this data should be used as a guide only.

---

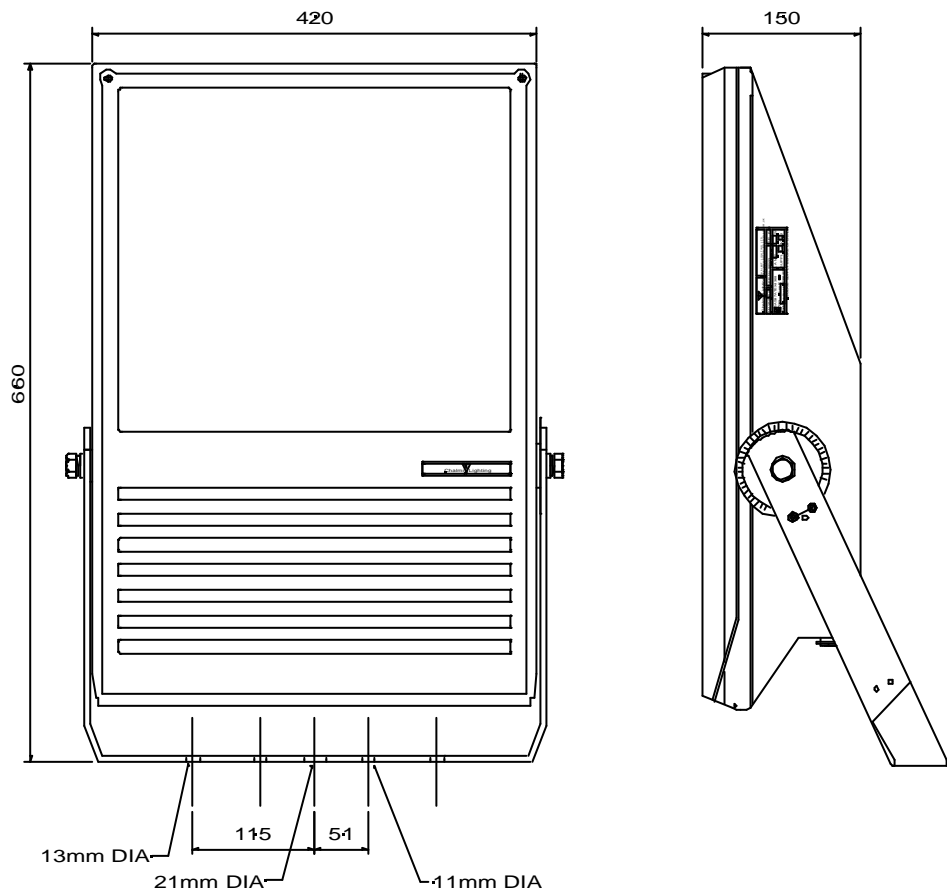

**0.0 Specification and ATEX Declaration**

|                     |   |
|---------------------|---|
| Type of Protection  | Ex nR (non-sparking) (restricted breathing)                   |
| Protection Standard | IEC 60079-15  |
| Area of Application | Zone 2 areas to IEC 60079-10 and installation to IEC 60079-14 |
| Equipment Coding    | Ex nR II T2/T3/T4 (Refer to Table 0 for Tamb)                 |
| IECEX Certificate   | IECEX certificate of conformity IECEX ITS 03.0004             |
| Ingress Protection  | IP66 and IP67 to IEC 60529                                    |

|  |  |
|--|--|
| <p>CE Mark</p>  | <p>The CE marking of this product applies to "The Electrical Equipment (Safety) Regulations 1994", "The Electromagnetic Compatibility Regulations 1992", the "Waste Electrical and Electronic Equipment Regulations 2006" and the "Equipment and Protective Systems intended for use in Explosive Atmospheres Regulations 1996". [This legislation is the equivalent in UK law of EC directives 73/23EEC, 89/336/EEC and 2002/96/EC respectively].</p> |
| <p>ATEX Declaration</p>  | <p>The Equipment is declared to meet the provisions of the ATEX directive (94/9/EC) by reason of the EC Type Examination and compliance with the Essential Health and Safety Requirements.<br/>I MacLeod Technical Manager</p>   |

**1.0 Introduction - Maxinex Floodlight**

**1.1 General**

The type of protection is Ex nR using a restricted breathing enclosure. It is available with wide (mottled) or narrow (specular) reflectors.

**Note :** *Lamp ranges, maximum ambient and surface temperature ratings are as outlined in TABLE 0.*

**1.2 Application**

The luminaire is designed to be safe in normal operation.  
 The luminaire should not be used in conditions where there are environmental, vibration or shock conditions above the normal for fixed installations.  
 The gaskets should not be exposed to hydrocarbons in liquid or high concentration vapour states.  
 The body material is made from marine grade aluminium, copper free.  
 The luminaire is suitable for applications where Ex n apparatus is used. The application is for ignitable gas atmospheres. The type examination does not address suitability for dusts or portable applications.

**2.0 Storage**

Luminaires and control gear boxes are to be stored in cool dry conditions preventing ingress of moisture and condensation. Any specific instructions concerning emergency luminaires must be complied with.

**3.0 Installation and Safety**

**3.1 General**

There are no health hazards associated with this product whilst in normal use. However, care should be exercised during the following operations. Installation should be carried out in accordance with IEC 60079-14 or the local hazardous area codes of practice whichever is appropriate.

Your attention is drawn to the paragraphs (i) 'Electrical Supplies', (ii) 'Electrical Fault Finding and Replacement' and (iii) 'Inspection and Maintenance'. The luminaires are Class 1 and should be effectively earthed.

The luminaires are quite heavy and suitable means of handling on installation must be provided.

Certification details on the rating plate must be verified against the application requirements before installation. The information in this leaflet is correct at the time of publication. The company reserves the right to make specification changes as required.

### 3.2 Tools

A cross head screwdriver blade to open the cover.

19mm A/F spanner, 3mm and 5mm flat blade screwdriver.

Pliers, knife, wire strippers/cutters.

### 3.3 Electrical Supplies

The supply voltage and frequency should be specified when ordering a maximum voltage variation of +6%/-6% on the nominal is expected. (The safety limit for T rating is +10%). Luminaires should not be operated continuously at more than +6%/-10% of the rated supply voltage of the control gear or tapping. The user must determine the **actual** underlying site supply and purchase or adjust accordingly. In some cases, the luminaires have multi-tapped control gear which can be set to a range of 50 and 60Hz voltages. The tapplings are shown on the control gear and the limits are shown on the rating plate. If the equipment is located in high or low voltage sections of the system, an appropriate voltage tap should be selected to obtain the best lamp performance, but care must be taken to log or mark the equipment so that the tapping is re-set if the equipment is relocated. If in doubt, tapplings should be set on the high side. 10V Max. drop is desirable for HPS and required for MBI. All circuits use S.I.P. (superimposed pulse) ignitors. This means that there are only two connections to the choke, so tap selection is obvious. Where supply conditions include significant harmonics, the PFC can be omitted. Where shore or construction site supplies are used, which are different to the service location supplies, tapplings should be re-set. If not, advice on the effect of these temporary supplies should be sought from the Technical Department.

### 3.4 Lamps

The discharge lamps used are of a standardised type. There is no preference between make or colour. All have E40 caps. The Maxinex uses tubular HPS and MBI lamps. Care must be taken to fit the correct new and replacement lamp in order to preserve the certification conditions and obtain the designed photometric performance. The lamp type is shown on the rating plate. **Lamps should be replaced shortly after they do not light.** One indication of the end of life for HPS lamps is 'cycling', where the lamp goes out then re-ignites after a minute or so interval. If discharge luminaires are burned continuously, they should be switched off occasionally to allow old lamps to fail to re-ignite, rather than possibly become diodes with detrimental effects to control gear. The above information is current at the time of preparation. The development of lamps and control gear is ongoing and detailed advice on lamp performance can be obtained from the lamp supplier or from Chalmit.

**Important :** *HPS and MBI circuits should not be energised without a lamp fitted. HPS and MBI lamps with internal ignitors must not be used.*

### 3.5 Mounting

Luminaires should be installed where access for maintenance is practical and in accordance with any lighting design information provided for the installation. This will usually consist of aiming points and aiming angles. The foot mounting or rear mounting arrangements should be secured with lock washers or self-locking nuts and bolts. The luminaire should be mounted with the lamp axis horizontal.

#### 3.5.1 Weights and Windages

**Note :** *Weights and Windages for the various types are outlined in Table 4.*

### **3.6 Cabling and Cable Glands**

#### **3.6.1 Cables**

The cable entry temperatures are given as the rise over the maximum rated ambient temperature. This allows the user to adjust the cable specification for actual site maximum temperature. The standard conductor section is 6mm<sup>2</sup> max. All models are suitable for looping except the 400W remote gear version. Standard 300/500V cable is suitable. The cable makeup must be suitable to ensure the obtaining of a restricted breathing enclosure when the cable gland assembly is fitted.

#### **3.6.2 Cable Glands**

Cable glands and sealing plugs when installed must maintain the restricted breathing enclosure. (Vacuum test; 300mm head of water, half pressure time 3 mins. minimum). Rubber sealing washers and steel compression washers are provided with the unit to seal between the gland body and the luminaire. The body torque value is 12Nm. The user must ensure that the assembly fulfils the above requirement. No means of checking the air tightness of the assembled unit is provided. When new sealing arrangements are to be installed, users should check a sample for substantial air tightness before making a full installation. Entries suitable for M20 cable glands are standard. Entries suitable for M25 are available to special order.

#### **3.6.3 Cable Gland Types**

Refer to the cable gland manufacturers catalogue for further information with regard to compatibility with cable types. Refer to Chalmit for the assessment of other suitable types. These will be covered by a manufacturers declaration.

**Note :** *Cable gland types covered by the type examination are as indicated in TABLE 1.*

### **3.7 Cabling and Fitting Lamps**

Access for cabling and fitting lamps is by removing the front cover. The cover is released by undoing the two screws using a screwdriver. Reselect the voltage tapping if necessary. Install the conductors in the appropriate terminals. Take care not to cut back the insulation excessively, 1 mm bare conductor outside the terminal is a maximum. Any unused terminal should be fully tightened. When the cabling is complete, make a final tightness and connection check. Lamps must be of the correct type and firmly screwed into place. The cover is replaced and the screws tightened down.

### **3.8 Inspection and Maintenance**

Visual inspection should be carried out at a minimum of 12 monthly intervals and more frequently if conditions are severe. The time between lamp changes could be very infrequent and this is too long a period without inspection.

#### **3.8.1 Routine Examination**

The equipment must be de-energised before opening. Individual organisations will have their own procedures. What follows are guidelines based on *IEC 60079-17* and on our experience :

- 1 Ensure the lamp is lit when energised and that the lampglass is not damaged.
- 2 When de-energised and left to cool, there should be no significant sign of internal moisture. If there are signs of water ingress, the luminaire should be opened up, dried out, and any likely ingress points eliminated by re-gasketting.
- 3 Check the cable gland for tightness and nip up if necessary.
- 4 Check the tightness of the cover screws and nip up if necessary.
- 5 Clean the lampglass.
- 6 When relamping, check that the cover gasket has not softened or become excessively deformed. If in doubt, replace ( See Section 4.0).

### 3.9 Electrical Fault Finding and Replacement

The supply must be isolated before opening the luminaire.

In most instances, the faults are simple, namely loose or broken connections, unserviceable lamps or open circuit control gear. Control gear will not normally go open circuit unless it has first over-heated; the signs of this are obvious, being severe discoloration of the paint on the gear and cracks in any exposed insulation. Similarly, a bad contact at the lamp cap will usually result in discoloration as a sign of overheating. Any fault finding must be done by a competent electrician and, if carried out with the luminaire in place, under a permit to work. With HPS and MBI, the ignitor can become faulty. If the lamp is fitted, the choke has continuity and the connections are good and correct, they should produce an "attempt to start" effect in the lamp and a buzzing sound from the ignitor. It will be unusual to have no other parts available to perform a substitution fault finding routine and this is the normal procedure. Before re-assembling, all connections should be checked and any damaged cable replaced. The ignition connection to the lampholder is sleeved with H.T. sleeving and this must be kept in place.

#### 3.9.1 Thermal Protector

Thermal protectors are included. If the lamp goes on and off over a timescale of several minutes, this could be the thermal protector operating. The causes are defective lamps/diode effects, gross over voltage or the choke beginning to fail and this should be investigated directly ( See Section 3.4 ).

#### 4.0 Overhaul

The unit is largely made of materials which are very corrosion resistant. This allows the unit to be completely stripped, cleaned, then re-built with new electrical parts as required. The internal wiring is 1.0mm<sup>2</sup> flexible, silicone rubber insulated. An H.T. sleeve is fitted to the ignitor cable. All the spares required are available. Please state the model number, lamp and reflector details. The seal at the cover is between the glass and the frame. The glass is retained in the cover frame by silicone R.T.V. adhesive. If the cover gasket has deteriorated by softening or permanent set, a new cover gasket should be fitted, which can be obtained from Chalmit. To fit this, care is needed, the old gasket should be removed and remaining adhesive scraped off with a chisel type blade. The gasket is fixed in place and joined with silicone R.T.V. to the body. The cover is tightened down and the assembly should be tested for air tightness prior to installation.

### 5.0 Fuse Ratings

The fuse ratings for HID lamp circuits need to take account of three components of circuit current. Current inrush to PFC capacitors which can be up to 25 x the rated capacitor current and last 1-2 milliseconds; lamp starting current including steady capacitor current which together may decline from up to 200% of normal at 10 seconds after switch-on to normal after 4 minutes; rectification effects caused by asymmetrical cathode heating for a few seconds after starting, this effect is random and very variable. With the availability of MCB's with a wide range of characteristics, the individual engineer can make a better judgement of what is required. Use MCB's suitable for inrush currents to reduce ratings. The inrush current can be calculated where circuit conditions are known. The nominal capacitor current will probably be the determining factor, 0.076A per  $\mu\text{F}$  at 240V, 50Hz (adjust for other supply volts by multiplication, x 6/5 for 60Hz). For HBC fuses use 1.5 x normal capacitor current. All calculations must satisfy wiring regulations.

**Note :** *Starting and running currents for 240V, 50Hz are as indicated in TABLE 2.  
A conventional matrix for HBC fuses is outlined in TABLE 3.*

### 6.0 Disposal of Material

The unit is mostly made from incombustible materials. The capacitor is of the dry film type and does not contain PCB's. The control gear contains plastic parts and polyester resin. The ignitor contains electronic components and synthetic resins. All electrical components and the body parts may give off noxious fumes if incinerated. Take care to render these fumes harmless or avoid inhalation. Any local regulations concerning disposal must be complied with. Any disposal must satisfy the requirements of the WEEE directive [2002/96/EC] and therefore must not be treated as commercial waste. The unit is mainly made from incombustible materials. The control gear

contains plastic, resin and electronic components. All electrical components may give off noxious fumes if incinerated.

**6.1 Lamps**

Incandescent lamps and discharge lamps in modest quantities are not "special waste". The outer envelope should be broken in a container to avoid possible injury from fragmentation. This applies to the UK, there may be other regulations on disposal operating in other countries.

**Important :** *Do not incinerate lamps.*



To comply with the Waste Electrical and Electronic Equipment directive 2002/96/EC the apparatus cannot be classified as commercial waste and as such must be disposed of or recycled in such a manner as to reduce the environmental impact.

**0.0 Tables 0/1/2/3/4**

Table 0 Lamp Ranges, Maximum Ambient and Temperature Ratings Refer to Section : 1.1

| Wattage | Lamp         | Ambient Temp<br>°C | T Rating | Cable Rating<br>°C | Cable Rise<br>°C |
|---------|--------------|--------------------|----------|--------------------|------------------|
| 150W    | SON/T, MBI/T | 55                 | T4       | 75                 | 20               |
| 250W    | SON/T, MBI/T | 55                 | T3       | 85                 | 30               |
| 400W    | SON/T        | 45                 | T3       | 85                 | 40               |
| 400W    | MBI/T        | 30                 | T3       | 75                 | 40               |
| 400W    | SON/T        | 50                 | 210(T2)  | 90                 | 40               |
| 400W    | MBI/T        | 50                 | 220(T2)  | 90                 | 40               |
| 400W    | SON/T*       | 55                 | 220(T2)  | 95                 | 40               |
| 400W    | MBI/T*       | 55                 | 230(T2)  | 95                 | 40               |

**Note :** *400W, 55°C versions are not fitted with PFC capacitors.*

Table 1 Cable Gland Types Refer to Section : 3.6.3

| Gland Type | Make                 |                 |                    |
|------------|----------------------|-----------------|--------------------|
|            | Hawk<br>Cable Glands | CMP<br>Products | BICC<br>Components |
| 311        | *                    |                 |                    |
| 321        | *                    |                 |                    |
| 352        | *                    |                 |                    |
| 353        | *                    |                 |                    |

|        |   |   |   |
|--------|---|---|---|
| 353T   | * |   |   |
| 354    | * |   |   |
| VBL321 | * |   |   |
| VBL352 | * |   |   |
| VBL353 | * |   |   |
| VBL354 | * |   |   |
| A2F    |   | * | * |
| E1FX   |   | * |   |
| E2FW   |   | * |   |
| E1FW   |   | * |   |
| A4e    |   | * |   |
| E1W    |   |   | * |
| E1X    |   |   | * |
| RTL    |   |   | * |

Table 2 Starting and Running Currents

Refer to Section : 5.0

| Lamp     | Lamp A | Start A | Run A | PFC $\mu$ F | Circuit Power (W) |
|----------|--------|---------|-------|-------------|-------------------|
| 150W HPS | 1.8    | 1.2     | 0.75  | 15          | 168               |
| 250W HPS | 3.0    | 2.35    | 1.3   | 20          | 286               |
| 400W HPS | 4.5    | 4.0     | 2.2   | 30          | 440               |
| 150W MBI | 1.8    | 1.2     | 0.75  | 15          | 170               |
| 250W MBI | 3.0    | 2.65    | 1.35  | 30          | 282               |
| 400W MBI | 4.2    | 4.4     | 2.2   | 40          | 440               |

Table 3 Fuse Ratings

Refer to Section : 5.0

| Lamp Wattage | Number of Lamps |     |     |     |     |     |
|--------------|-----------------|-----|-----|-----|-----|-----|
|              | 1               | 2   | 3   | 4   | 5   | 6   |
| 150W         | 4A              | 6A  | 10A | 10A | 16A | 16A |
| 250W         | 10A             | 16A | 16A | 20A | 20A | 20A |
| 400W         | 16A             | 20A | 20A | 25A | 25A | 32A |

Table 4 Weights and Windages

Refer to Section : 3.5.1

| Type        | Weight | Windage            |
|-------------|--------|--------------------|
| MAXINEX 400 | 17.0kg | 0.25m <sup>2</sup> |

|             |        |                    |
|-------------|--------|--------------------|
| MAXINEX 250 | 15.5kg | 0.25m <sup>2</sup> |
| MAXINEX 150 | 14.5kg | 0.25m <sup>2</sup> |

Chalmit Lighting  
PO Box 5575  
Glasgow  
G52 9AP  
Scotland

Telephone : +44 (0) 141 882 5555  
Fax : +44 (0) 141 883 3704  
Email : [info@chalmit.com](mailto:info@chalmit.com)  
Web : [www.chalmit.com](http://www.chalmit.com)

For technical support, please contact: [techsupport@chalmit.com](mailto:techsupport@chalmit.com)

**Registered Office :**

Mitre House,  
160 Aldersgate Street,  
London,  
EC1A 4DD

Registered No: 669157

**Note :**

Chalmit Lighting reserve the right to amend characteristics of our products, and all data is for guidance only.



Chalmit Lighting is a leading supplier of Hazardous Area and Marine Lighting products.