

INSTALLATION, OPERATION AND MAINTENANCE INSTRUCTIONS

Protecta St.St. Ind. Area Fluorescent Luminaire

Important : Please read these instructions carefully before installing or maintaining this equipment. Good electrical practices should be followed at all times and this data should be used as a guide only.

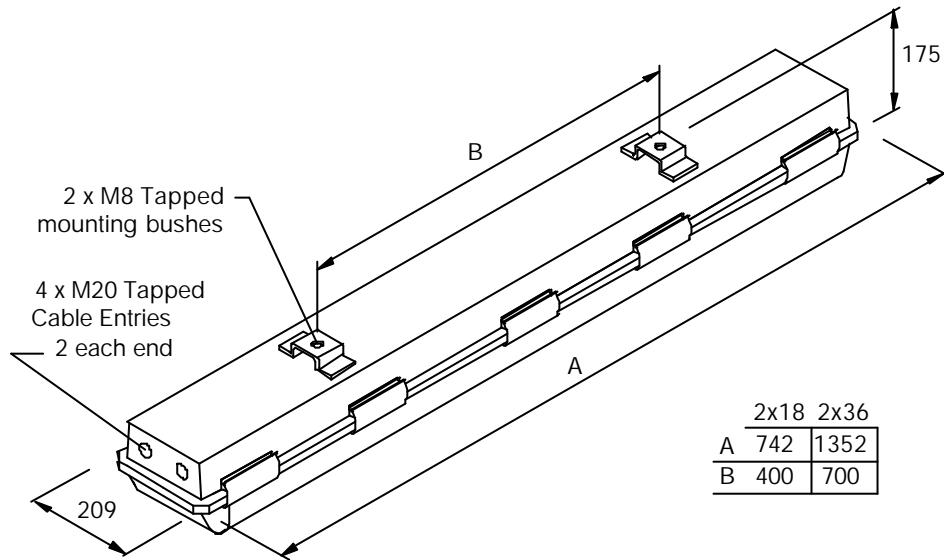

0.0 Specification

Type Of Protection	N/A
Area Classification	Non-Hazardous
Standard	BS EN 60598 Pt 1
Ingress Protection	Temperature Range T amb 50°C IP66/67 to BS EN 60529

CE Mark



The CE marking of this product applies to "The Electrical Equipment (Safety) Regulations 1994", "The Electromagnetic Compatibility Regulations 1992", the "Waste Electrical and Electronic Equipment Regulations 2006" and the "Equipment and Protective Systems intended for use in Explosive Atmospheres Regulations 1996". [This legislation is the equivalent in UK law of EC directives 73/23EEC, 89/336/EEC and 2002/96/EC respectively].

1.0 Introduction - Protecta Safe Area Fluorescent Luminaire

The Protecta Safe Area fluorescent luminaires are surface mounted or suspended, utilising the two tapped holes on base of body, with the facility of an integral battery back-up for emergency use. Normal operation is mains supply two lamps on, switching to one lamp on battery back-up, local switching of the mains lamps, the emergency lamp only being energised on mains failure. Emergency duration: to BS EN 60598 2.22, as per order. They are mainly used in harsh environments, and are constructed using a stainless steel body (option of painted) attached to an injection moulded polycarbonate diffuser by hinges and a special clamp. The control gear and lampholders are mounted on a removable tray which for maintenance has hanging straps.

Note : *Ratings using copper/iron switch start control gear are as indicated in TABLE 0.*

2.0 Storage

Luminaires and control gear boxes are to be stored in cool dry conditions preventing ingress of moisture and condensation. Any specific instructions concerning emergency luminaires must be complied with.

3.0 Installation and Safety

3.1 General

There are no health hazards associated with this product whilst in normal use. However, care should be exercised during the following operations.

In the UK the requirements of the '*Health and Safety at Work Act*' must be met.

Handling and electrical work associated with this product to be in accordance with the '*Manual Handling Operations Regulations*' and '*Electricity at Work Regulations, 1989*'. Your attention is drawn to the paragraphs (i) 'Electrical Supplies', (ii) 'Electrical Fault Finding and Replacement' and (iii) 'Inspection and Maintenance'. The luminaires are Class 1 and should be effectively earthed.

The information in this leaflet is correct at the time of publication. The company reserves the right to make specification changes as required.

3.2 Tools

12mm, 8mm and 4mm flat blade screwdriver.

Suitable spanners for installing cable glands.

Pliers, knife, wire strippers/cutters.

3.3 Electrical Supplies and Control Gear

The supply voltage and frequency should be specified when ordering. A maximum voltage variation of +6%/-6% on the nominal is expected. Luminaires should not be operated continuously at more than +6%/-10% of the rated supply voltage of the control gear or tapping. **Care is needed connecting to the nominal 230V UK public supply.** The user must determine the actual underlying site supply and purchase or adjust accordingly. Normally, luminaires for 230V and 240V, 50Hz rating and which use a conventional copper/iron choke, are supplied with a tap.

If the equipment is located in high or low voltage sections of the system, an appropriate voltage tap should be selected, but care must be taken to log or mark the equipment so that the tapping is re-set if the equipment is re-located. If in doubt, tapings should be set on the high side.

Luminaires fitted with electronic control gear are suitable for a rated supply between 220 and 240V, 47-63Hz, and for higher voltages to order. The safety limits are +10% of this. The supply would normally be expected to lie within +/-6% of rated. The lamp supply is regulated, therefore the light output over the range is substantially unchanged.

Some luminaires are available for operation on dc and 110/130V and 277V ac. Operation from dc should be checked with the Technical Department before ordering. Electronic gear has integrated power factor correction to >0.95.

Warning : *Luminaires are assessed and/or tested for EMC requirements. This is based on the disposition of entry cables and, where appropriate, through wiring arrangements as supplied or specified. Users must take care not to introduce wiring into parts of the apparatus materially different to that which could be reasonably inferred from the disposition of fixed supply terminals and specified through wiring.*

3.4 Lamps

Lamps are bi-pin fluorescent tubes having the following ratings, 18W and 36W (T8) 26mm diameter tubes.

3.5 Mounting

Luminaires should be installed where access for maintenance is practical and in accordance with any lighting design information provided for the installation.

3.6 Cable Connection

3.6.1 Cables

The temperature conditions of the supply cable entry point are such that 70°C (ordinary PVC) cable can be used. On models where there is no fixed through wiring supplied by Chalmit, but where there is a looping facility on the gear tray, any supply wiring passing through the body must either have a rating of 130°C or have sleeving fitted which has a 130°C rating. 300/500V cable ratings are adequate and no special internal construction is necessary. Where MCB's are used, the type with the higher short time tripping current ratio used for motor starting and lighting should be specified. The standard maximum looping size is 2.5mm² with options of 4mm² through wiring. An internal earth tag can be fitted to the cable gland.

3.6.2 Cable Glands

Cable glands when installed should maintain the desired IP rating of the enclosure.

3.7 Electrical Connections

Luminaires are available for looping and through wiring. The through rating is 16A. Terminals for 4mm² and 6mm² are available. State which on order. If work is to be done on any luminaire which has already been connected to the electrical system, it must be isolated from the system. The diffuser cover is swung down and removed if convenient by swivelling back as far as possible and the reflector tray is then slid out after releasing the locking screws. This gives access to the mains terminals. Luminaires with terminal blocks have L N E, where appropriate.

3.7.1 Installation of HF and Emergency

Following the mounting of the apparatus and the connection of the supply cable the unit **cannot** be insulation tested. When the unit is ready for operation the mains and the battery connections must be made, the unit is supplied with the battery disconnected. After commissioning the unit can be shut down for a long period without loss of function.

3.8 Servicing and Operation

3.8.1 Opening and Closing the Cover

The procedure for opening the cover is as follows:

Insert the tool into one of the slots in the clamping bar with the end of the tool located into the outer flange of the body as a fulcrum point, a wide blade screwdriver is recommended. Gently lever the tool away from the diffuser, the clamping bar will begin to open. Insert the tool in the other clamping bar slot and gently lever away from the diffuser, the clamping bar will open and the cover will be retained by the hinge. Should difficulty be experienced, reinsert the tool in the first slot and repeat the procedure.

The procedure for closing and securing the cover is as follows :

Ensure the hinge mechanism is clear of any obstruction and then swing the diffuser into the closed position. Support the diffuser in position whilst pushing the clamp bar over the edge of the diffuser. Apply even pressure at both ends of the bar and press the bar over centre.

3.8.2 Removal and Replacement of Clamping Bar (if required)

Open the luminaire as above and remove the diffuser or let it swing down. Press the clamping bar towards the closed position, tip forward beyond the closed position and the clamping bar will be released from the body. To replace the clamping bar, put in position on the body with the front edge pointing as far inwards as it will go. Click the bar outwards and bring back to the normal closed position. The clamping bar should then be secured in position, open the clamping bar fully by using hand or screwdriver pressure (avoid damaging the gasket), the clamping bar is then ready to accept the normal closure of the diffuser.

3.8.3 Releasing the Reflector/Gear Tray

Loosen the four fixing screws retaining the reflector/gear tray and slide over keyhole slots. The tray will hang on the retaining cords without stressing the wiring between body and tray. Replace in reverse order.

3.8.4 Fitting lamps

The bi-pin lamps are fitted in rotating lampholders. The lamp should be pushed firmly down into the lampholder and rotated 90°. If the lamp does not rotate check that it is completely positioned into the lampholder. There will be a slight click when the lampholder reaches the 90° position. Before inserting bi-pin lamps ensure the lamp pins are not slack in the end cap.

3.8.5 Commissioning

Energise the mains and check that both lamps light when the supply is energised.

3.9 Inspection and Maintenance

On battery models, we recommend that the battery duration is checked periodically.

Important : *Isolate the mains supply and disconnect the battery terminal before carrying out any work.*

3.9.1 Replacement of Electronic Ballast and Invertor Unit (Where Fitted)

The electronic ballast and invertor contain no replaceable parts. Should it be found necessary to replace these parts, the following procedure should be adopted:

Ensure that the luminaire is isolated from both mains and battery supplies, otherwise a risk of shock may occur. Disconnect the leads on the ballast at the terminal block. Undo the ballast securing screws and washers and withdraw the ballast from the gear body. Replace in reverse order. Replacement of the invertor is identical.

3.9.2 Routine Examination

The luminaire must be de-energised before opening. Individual organisations will have their own procedures. What follows are guidelines based on our experience :

- 1 Ensure lamps are lit when energised by mains supply.
- 2 Visually check diffuser cover for damage, this should only be cleaned using a damp cloth to avoid static, and only use recommended detergents for polycarbonate. If the polycarbonate is discoloured or damaged a new diffuser cover must be fitted.
- 3 When de-energised and left to cool, there should be no significant sign of internal moisture. If there are any signs of water ingress, the luminaire should be opened up, dried and any likely ingress points eliminated by re-gasketing or other replacements.
- 4 Check cable gland for tightness and nip up if required.
- 5 Check any external and internal earths.
- 6 Check all terminations are firmly screwed down, tighten if necessary.
- 7 Check clips visually for any damage and replace, if necessary.
- 8 If it has been suspected that the luminaire has suffered mechanical damage, a stringent workshop check on all components should be made. All components can be removed from the luminaire for inspection.

4.0 Electrical Fault Finding and Replacement

The supply must be isolated before opening the luminaire.

Any live fault finding must be done by a competent electrician and, if carried out with luminaire in place, under a permit to work.

The control gear can be tested for continuity of connections with a low voltage tester.

If lamps go out repeatedly, and replacement lamps do not work or expected life is reduced, the control gear should be returned for replacement/testing.

On re-assembly all faulty/damaged wiring should be replaced and connections checked. If an electronic starter is fitted it will cut out if lamps are defective. Ordinary starters will blink continuously.

5.0 Disposal of Material

The unit is made from combustible materials. The capacitor is of the dry film type and does not contain PCB's. The control gear contains plastic parts and polyester resin. The ignitor contains electronic components and synthetic resins. All electrical components and the body parts may give off noxious fumes if incinerated. Take care to render these fumes harmless or avoid inhalation. Any local regulations concerning disposal must be complied with. Any disposal must satisfy the requirements of the WEEE directive [2002/96/EC] and therefore must not be treated as commercial waste. The unit is mainly made from incombustible materials. The control gear contains plastic, resin and electronic components. All electrical components may give off noxious fumes if incinerated.

5.1 Lamps

Fluorescent lamps in modest quantities are not "special waste". They should be broken up in a container to avoid injury. Avoid inhaling dust.

Important : *Do not incinerate lamps.*

5.2 Battery Disposal

Nickel cadmium batteries are defined as 'controlled waste' under the hazardous waste regulations and disposer needs to observe a 'duty of care'.

Batteries can be returned to the manufacturers for re-cycling. They must be stored and transported safely and any necessary pollution control forms completed prior to transportation. Take care to fully discharge batteries before transporting, or otherwise ensure that there can be no release of stored energy in transit. For further details refer to our Technical Department.

To comply with the Waste Electrical and Electronic Equipment directive 2002/96/EC the apparatus cannot be classified as commercial waste and as such must be disposed of or recycled in such a manner as to reduce the environmental impact.



0.0 Tables 0

Table 0 Ratings – Copper/Iron Switch Start Control Gear Refer to Section : 1.0

No. off Lamp	Lamp Watts	Lamp Circuit Type	Power Consumption Watts	PFC μ f	Line Current
1	18	Series	24.3	4	0.16
2	18	Parallel	48.6	6	0.32
2	18	Series	42.0	4	0.23
1	36	Series	42.0	4	0.23
2	36	Parallel	84.0	8	0.46

Note: For information on high frequency ballasts contact the Technical Department.

Chalmit Lighting
PO Box 5575
Glasgow
G52 9AP
Scotland

Telephone : +44 (0) 141 882 5555
Fax : +44 (0) 141 883 3704
Email : info@chalmit.com
Web : www.chalmit.com

For technical support, please contact: techsupport@chalmit.com

Registered Office:

Mitre House,
160 Aldersgate Street,
London,
EC1A 4DD

Registered No: 669157

Note :

Chalmit Lighting reserve the right to amend characteristics of our products, and all data is for guidance only.



Chalmit Lighting is a leading supplier of Hazardous Area and Marine Lighting products.