



The 261 with external reflector



The 261 with wire guard

The 261 is an efficient high wattage wellglass for general task area and highbay lighting. The luminaire has a side mounted increased safety terminal chamber eliminating the need for flameproof glands.

The 261 is suitable for low temperature operation (-40°C) with high pressure sodium lamps.

Standard Specification

Features

Type of Protection	Ex d e (Flameproof, Increased Safety)
ATEX Classification	Group II Category 2 G
Area Classification	Zone 1 and Zone 2 areas to EN 60079-10-1 with installation to EN 60079-14 Gas Groups IIA and IIB
Certificate	EC Type Examination Certificate BAS01ATEX2309
Coding	⊕ II 2 G Ex d e IIB Refer to table for T rating and Ambient
Enclosure	Aluminium alloy LM6 to BS 1490 (AC44100) All fastenings A4 stainless steel Toughened glass dome globe
Reflector	High purity anodised aluminium
Entry	2 x M20 cable entries
Termination	3 core 6mm ² max. conductor with looping
Installation	Stirrup mounting bracket
Windage	0.197m ²
Control Gear	Internal copper/iron with PFC correction capacitor
Relamping	Access via front glass cover assembly
Burning Position	Universal
Ingress Protection	IP66/67 to EN 60529
Electrical Supply	220, 230, 240, 254V 50Hz (HID) 110V - 240V ac/dc (GLS)

Installation to gas groups IIA and IIB

Ex e terminal chamber

Stainless steel fasteners

Anchor chain on glass cover assembly

Low temperature applications to -40°C

International Approvals

ATEX and GOST

IECEX Compliant

Std. Cat No.	Wattage	Lamp	TClass	Ambient °C	Weight
261D/150/HS	150W	HPS	T4	-40 to +50	31kg
261D/250/HS	250W	HPS	T4	-40 to +50	32kg
261D/400/HS	400W	HPS	T4	-40 to +50	33kg
261D/125/MV	125W	Mercury Vapour	T4	-20 to +50	31kg
261D/250/MV	250W	Mercury Vapour	T4	-20 to +50	32kg
261D/400/MV	400W	Mercury Vapour	T4	-20 to +50	33kg
261D/250/MH	250W	Metal Halide	T4	-40 to +50	32kg
261D/400/MH	400W	Metal Halide	T4	-40 to +50	33kg
261D/500/GL	Up to 500W	GLS	T4 T3	-40 to +45 -40 to +50	29kg 29kg
261D/125/MV/F*	125W	Mercury Vapour	T4	-40 to +70	31kg

*F - Flush / Pendant Mounted Version.

Note: When the external reflector is fitted with the flush/pendant version, the 'T' class and ambients stated above apply. When fitted to the stirrup mounted version the 'T' class changes to T3 with the ambient remaining the same.

Note: Please specify voltage at time of enquiry/order

Options – Suffix to Catalogue No.			
/P	PTFE coating	/60	60Hz
/M25	M25 cable entries	/TI	Timed ignitor

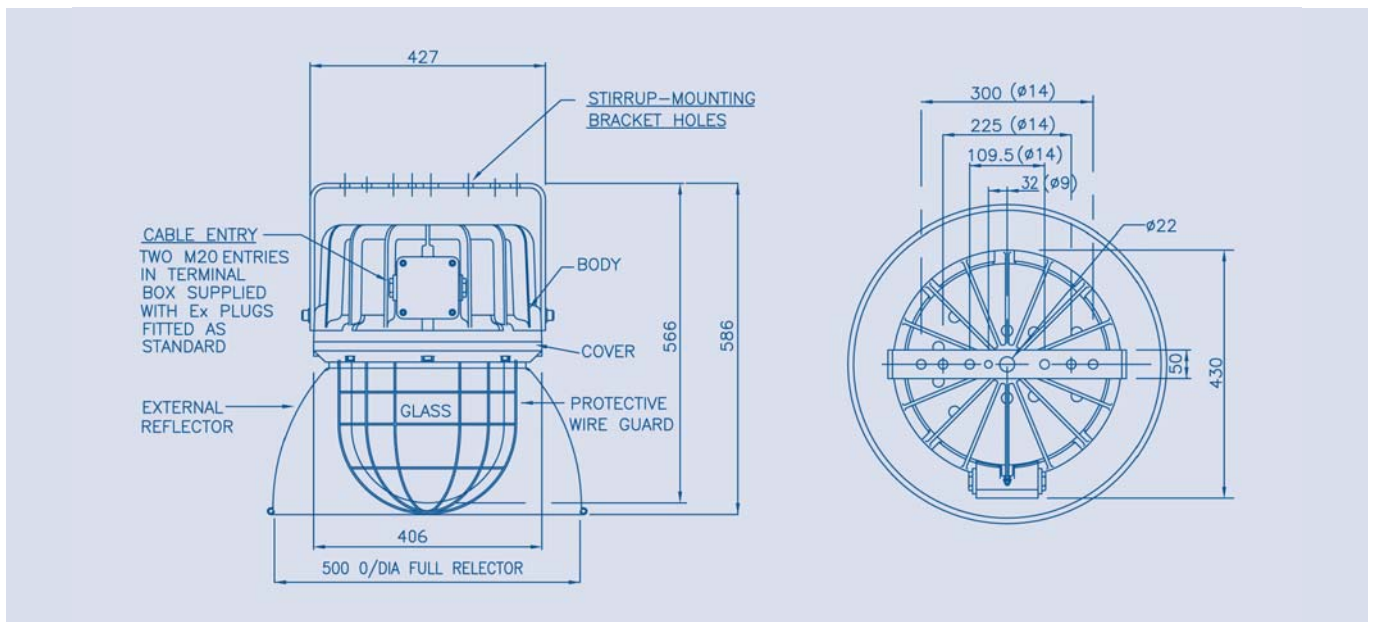

Accessories Should be ordered separately	Catalogue Order Code
Pole mounting bracket assembly (42-64mm diameter poles)	S2610-0001
Wire guard	S2610-0003
External reflector	S2610-0007

Product design and specifications are subject to change without notice, please check the Chalmit website for latest specifications.

