



The Acclaim is a recessed fluorescent specifically designed for use in solid or plank ceiling types. The luminaire is SOLAS B15 approved and suitable for use in offshore accommodation modules for both task and emergency lighting.

To allow safe and easy maintenance Acclaim features automatic lamp de-energisation upon opening. An emergency version with internal battery is also available.

Standard Specification		Features
Ingress Protection	IP54 to EN60529	Suitable for various ceiling types
Enclosure	White polyester painted zintec body and frame. Clear polycarbonate diffuser	Quick release mains terminals
		Resistant to voltage fluctuations
Entries	4 x 20mm clearance holes (supplied plug)	Local switching arrangement as standard
Internal Wiring	Stranded, heat resistant wiring up to 105°C	Electronic control gear gives 50/60Hz operation, high power factor correction and regulation of lamp output
Termination	Quick release mains terminals - 3 core 4mm ² max. conductor with looping and through wiring facility (4 core on emergency). (6mm ² terminations available - /SC option)	
Mounting	Swing out side arms (also suitable for drop rod mounting through 9mm holes)	dc operation (non emergency)
		3 hour emergency duration
Control Gear	High Frequency	B15 SOLAS fire rating - appropriate insulation is required over the luminaire
		Optional battery monitoring and self-testing control gear
Relamping	Via front cover, secured by pan head screws	
Electrical Supply	110-254V 50/60Hz, 220-254V 50/60Hz (emergency model) Always state V/Hz when ordering	
Battery duration	3 Hours (emergency models)	

Std. Cat No.	Wattage	Lamp Type	Lampholder	Weight
ACLI/218/BI	2x18W	T8 Fluorescent	G13	6.0kg
ACLI/236/BI	2x36W	T8 Fluorescent	G13	11.0kg
ACLI/218/BI/EM	2x18W	T8 Fluorescent	G13	8.5kg
ACLI/236/BI/EM	2x36W	T8 Fluorescent	G13	13.5kg

Options – Suffix to Catalogue No.

/120 Specific voltage (110/130 - Emergency version only)	/SC Screwed connection terminal block (up to 6mm ² conductors)
/PC Solid ceiling	/DIM Analogue dimming
/3P 3 phase termination facility (not available if through wiring required)	/LG Low glare louvre
/EL Extra live termination facility (compatible with 4 core switched emergency circuits)	/PD Prismatic diffuser
/25 25mm cable entries	/BMT Battery monitoring and self-test
/MF Mains fuse	/SSCS Brushed stainless steel cover (M300 ceiling only)
	/SSC/PC Brushed stainless steel cover (Solid ceiling only)

Please refer overleaf for ceiling types

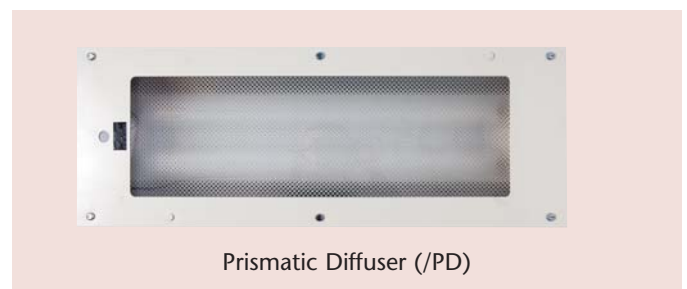

Product design and specifications are subject to change without notice, please check the Chalmit® website for latest specifications.



M300 Plank Ceiling Types

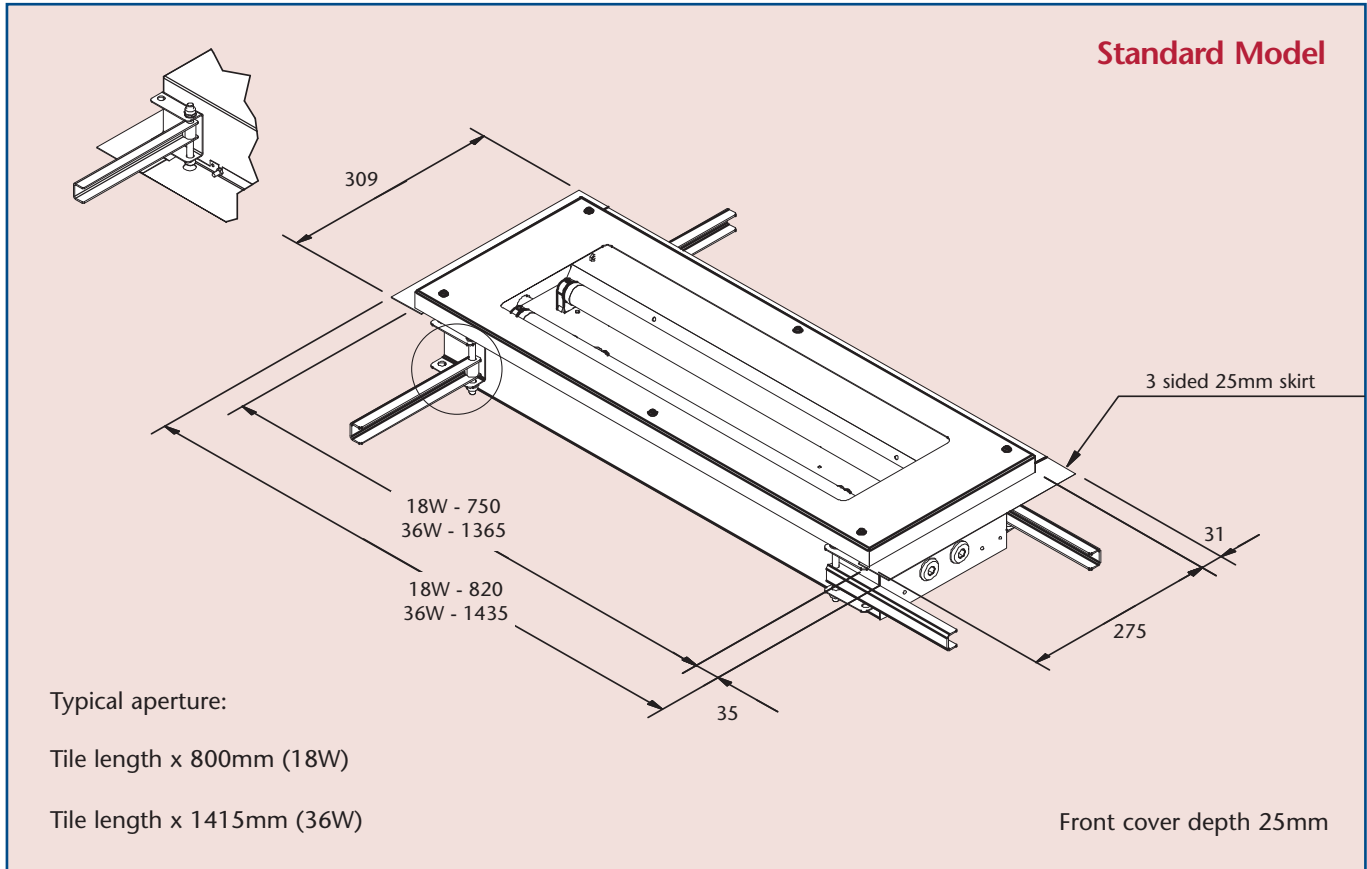

Front view of recessed luminaire

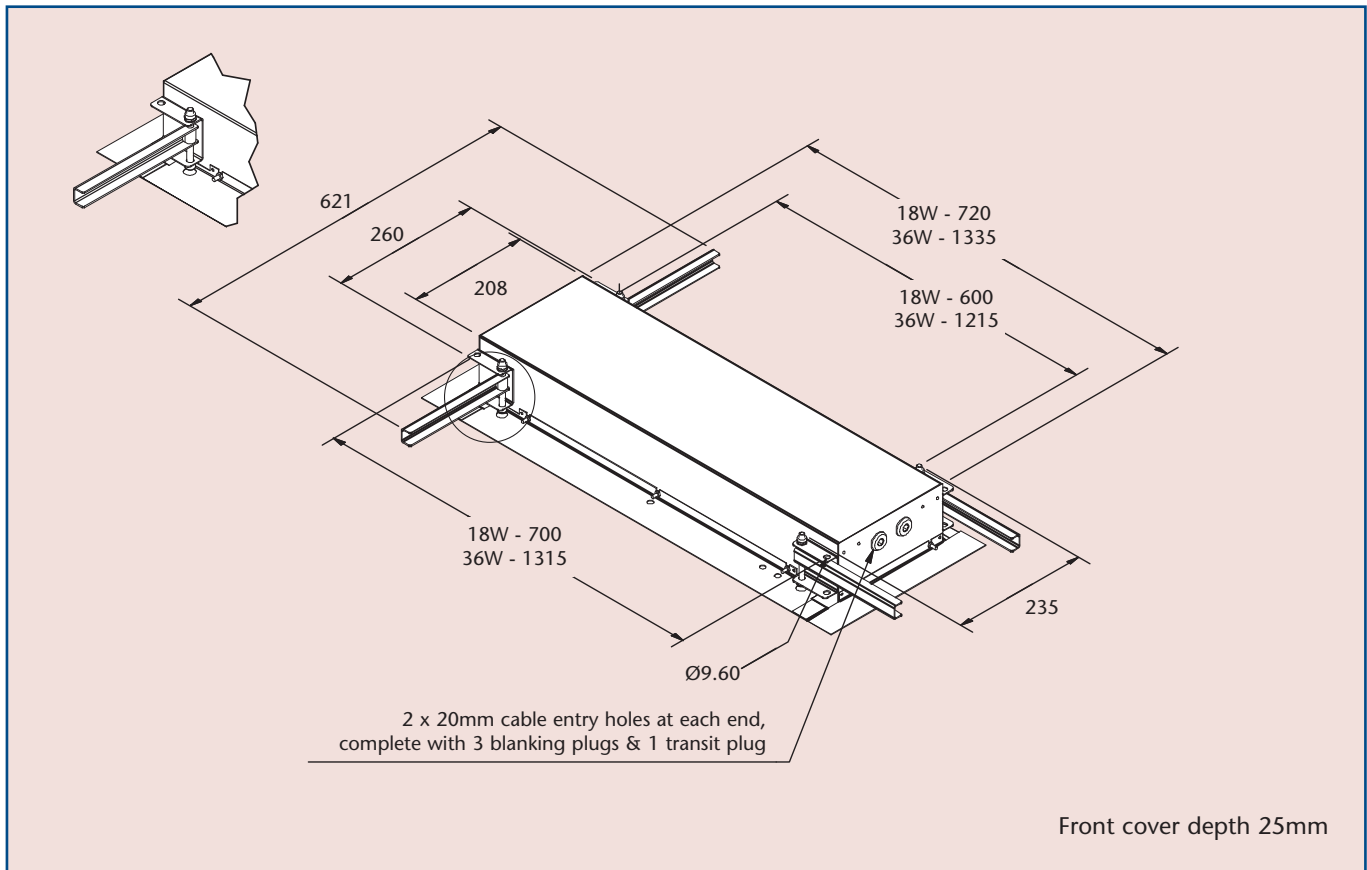

Rear view of recessed luminaire

Solid Ceiling Types

/PC Model

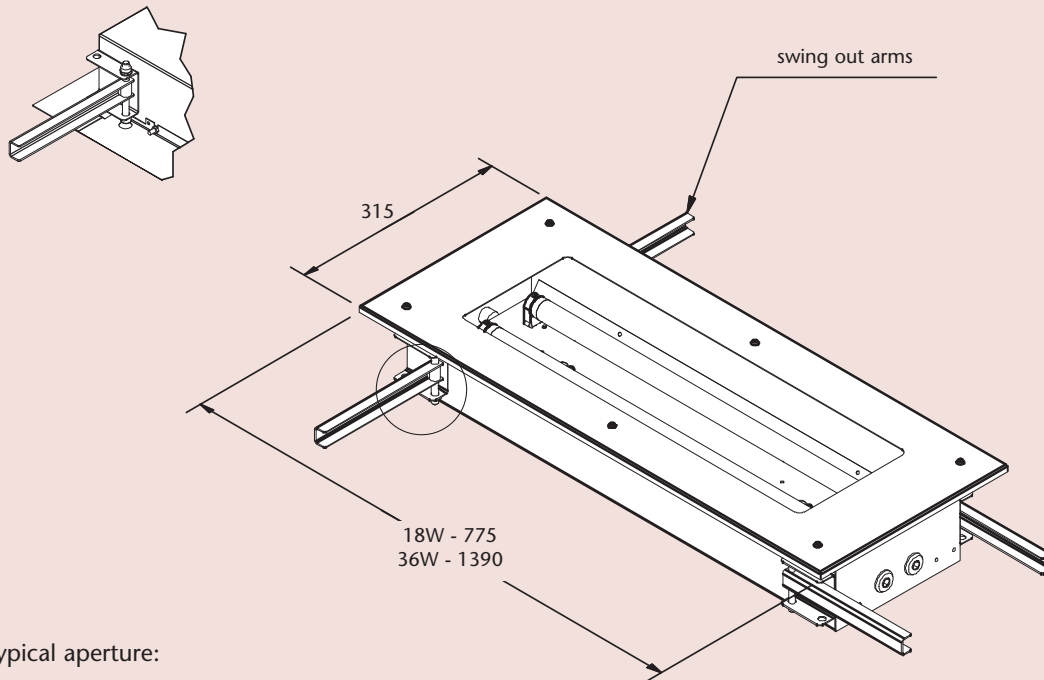

Typical aperture:

(18W) : 300mm x 745 (+/-5mm)

(36W) : 300mm x 1360 (+/-5mm)

Front cover depth 10mm

Front view of recessed luminaire

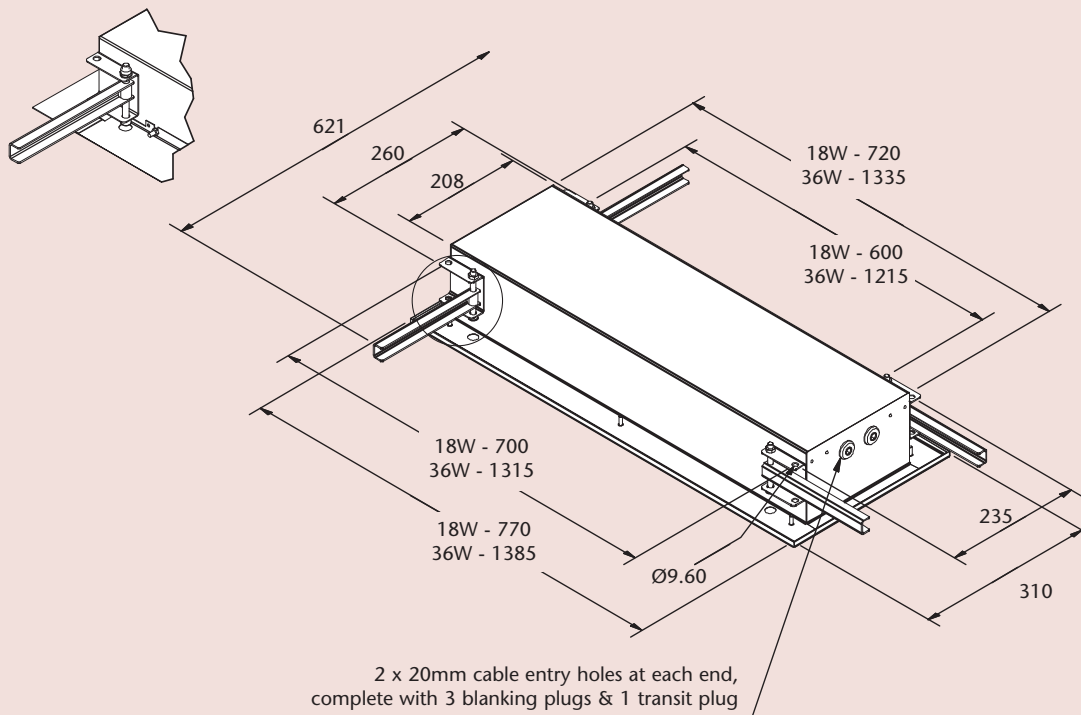

Front cover depth 10mm

Rear view of recessed luminaire

