



The Eclipse Junior with external reflector



The Eclipse Junior with wire guard

The Eclipse Junior is a compact wellglass that incorporates the low maintenance features of the Eclipse II.

Its low profile design and range of mounting options, offers an all round lighting solution in areas of limited space.

Standard Specification

Features

Ingress Protection	IP66/67 to EN60529
Enclosure	Painted aluminium body with glass globe Silicone rubber gasket
Entries	1 x M20 cable entries
Termination	3 core 6mm ² max conductors
Reflector	Wide beam high purity anodised aluminium
Mounting	Ceiling mounted
Windage	0.066m ²
Control Gear	Refer to universal control gear box for models with HPS or Metal Halide lamps
Relamping	Via end cover secured by stainless steel screws
Electrical Supply	250V Max ac/dc for tungsten halogen lamps

Compact size and low weight

Easy access for wiring and control gear

Corrosion resistant

Excellent light distribution

Std. Cat No.	Wattage	Lamp Type	Lampholder	Weight
ECJI/050/HS	50W	HPS	E27	5.5kg
ECJI/070/MS	70W	HPS/Metal Halide	E27	6.0kg
ECJI/080/MV	80W	MBFU	E27	6.0kg
ECJI/125/MV	125W	MBFU	E27	6.5kg
ECJI/150/GLS	150W	GLS	E27	5.0kg

For mounting options refer to page 94.

Note: Please specify voltage at time of enquiry/order

Options – Suffix to Catalogue No.			
/60	60Hz	/ST	Stanchion mounted version
/WM	Wall mounted version	/PE	Pendant mounted version

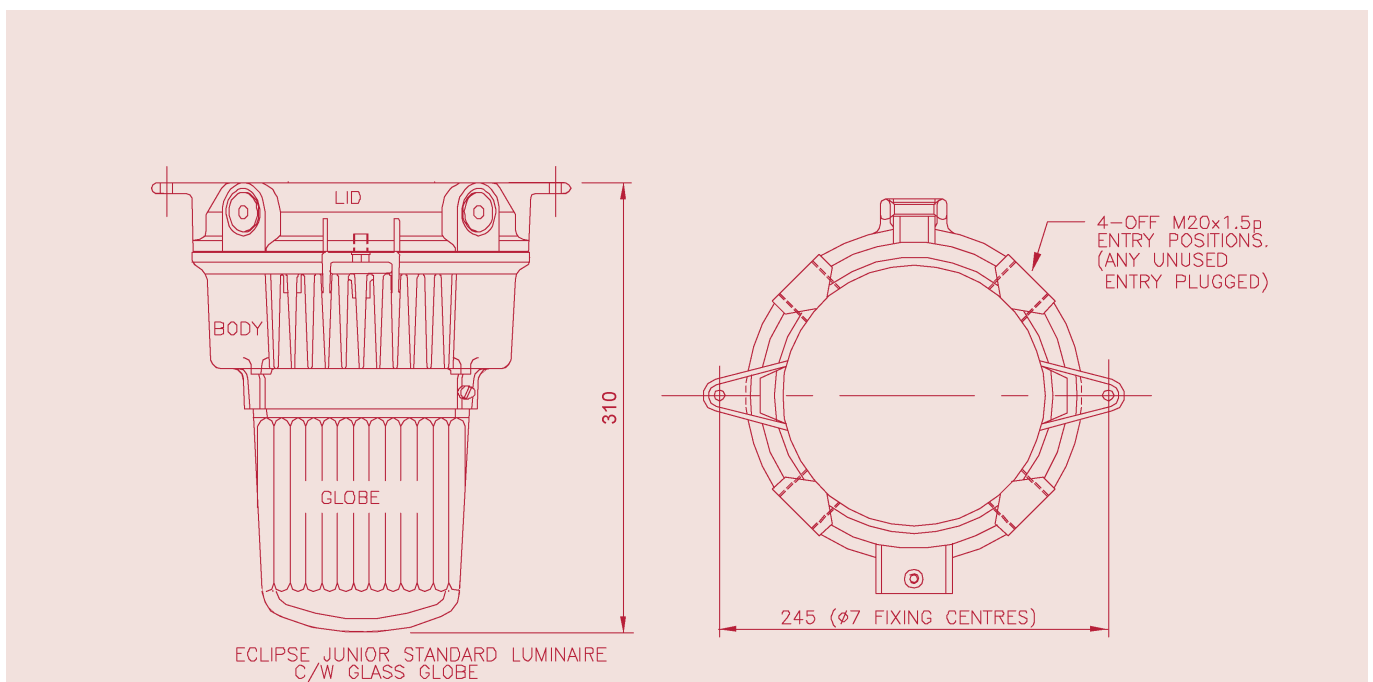

Accessories	Should be ordered separately	Catalogue Order Code
Wire guard (can be used in conjunction with reflectors)		E0850-0048
Dome reflector		SECL0-0001
30° Angled reflector		SECL0-0002

Product design and specifications are subject to change without notice, please check the Chalmit website for latest specifications.

