



The Evolution Junior is a lightweight and portable version of the advanced Evolution floodlight. It features the same single bolt access and has a range of floor and tripod stands for a variety of temporary applications.

Standard Specification

Features

Type of Protection	Ex d e (Flameproof, Increased Safety)
ATEX Classification	Group II Category 2 G
Area Classification	Zone 1 and Zone 2 areas to EN 60079-10-1 with installation to EN 60079-14. Gas Groups IIA, IIB and IIC
Certificate	EC Type Examination Certificate BAS99ATEX2228
Coding	⊕ II 2 G Ex d e IIC Refer to table for T rating and Ambient
Enclosure	Aluminium alloy LM6 to BS 1490 (AC44100) All fastenings A4 stainless steel Toughened glass window
Reflector	Wide beam, high purity anodised aluminium
Entry	2 x M20 cable entries
Termination	3 core 6mm ² max. conductor with looping
Installation	Stirrup mounting bracket
Windage	0.094m ²
Control Gear	Internal copper/iron with PFC correction capacitor
Relamping	Access via hinged end cover on release of single screw
Burning Position	Universal for HID, +/-45° on horizontal axis for Tungsten-Halogen Lamps
Ingress Protection	IP66/67 to EN 60529
Electrical Supply	220, 230, 240, 254V 50Hz (HID) 24V(ac/dc)-250V (dependant on voltage)

Installation in gas groups IIA, IIB and IIC

Easy and quick access for maintenance

Simple, rapid lamp replacement and flamepath inspection

Exceptional photometric efficiency

Available with secondary protective glass for shot blasting applications

International Approvals

ATEX, GOST CEPEL and TIS

Std. Cat No.	Wattage	Lamp	Lampholder	T Class	Ambient °C	Weight
EVJD/070/MS	70W	HPS and Metal Halide	E27	T4	40	12kg
				T3	55	12kg
EVJD/300/TL	150W	Tungsten-Halogen	R7s	T3	55	10kg
	200W	Tungsten-Halogen	R7s	T3	40	10kg
	250W	Tungsten-Halogen	R7s	T3	20	10kg
				T2	50	10kg
	300W	Tungsten-Halogen	R7s	T2	40	10kg
EVJD/150/TL/24	150W 24V	Tungsten-Halogen	R7s	T3	55	10kg
Secondary Glass Shield Cat Nos.						
EVJD/300/TL/GS	150W	Tungsten-Halogen	R7s	T3	55	10kg
	200W	Tungsten-Halogen	R7s	T3	25	10kg
	200W	Tungsten-Halogen	R7s	T2	50	10kg
	250W	Tungsten-Halogen	R7s	T2	40	10kg
EVJD/300/TL/24/GS	150W 24V	Tungsten-Halogen	R7s	T3	55	10kg

Note: Please specify voltage at time of enquiry/order

Options – Suffix to Catalogue No.

/60	60Hz	/FS	Suitable for use with floor stand (floor stand should be ordered separately)
/M25	M25 cable entries	/CG	Cable and Ex gland fitted (order cable separately - see accessories)
/P	PTFE coating	/CGP	Cable, Ex gland and 110V plug (cable should be ordered separately)
/Y	Yellow painted version (110V only)	/GS	Secondary glass (factory fitted)
/LT	Low temperature version -50°C (IIA & IIB only)		

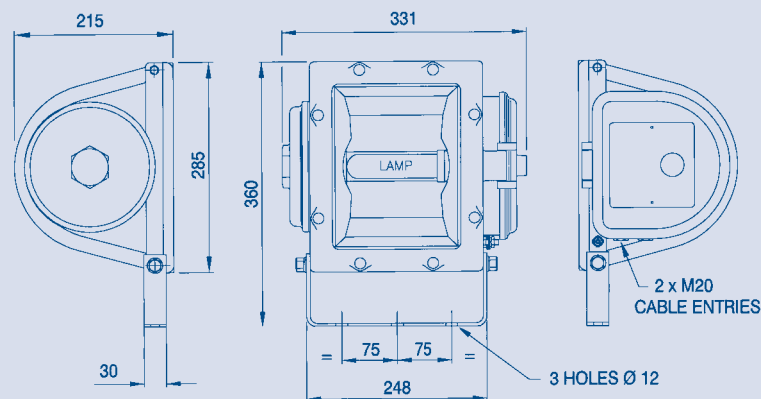

Accessories Should be ordered separately

Catalogue Order Code

Pole mounting bracket assembly (48-70mm diameter poles)	SEVJ4-0003
Anti-glare shield	SEVJ4-0001
Wire guard	SEVJ4-0002
Floor stand assembly (to be ordered with floor stand version of floodlight)	SEVJR-0001
Tripod stand assembly	SEVJR-0002
Ratchet handles (2 off) for adjustable aiming	SEVJR-0005
Cable (ordered per metre)	E0414-0009

Product design and specifications are subject to change without notice, please check the Chalmit website for latest specifications.



EVOLUTION RANGE

3

Evolution II & Evolution Guards and Shields

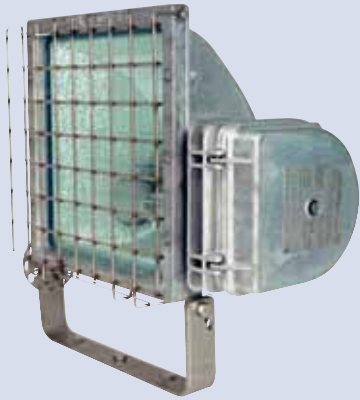

Evolution II	
Wire Guard	SEV04-0020
Evolution	
Anti-Glare Shield	SEV04-0002
Wire Guard	SEV04-0003
Combined Anti-Glare Shield and Wire Guard	SEV04-0008

Evolution Anti-Glare Shield

Combined Anti-Glare Shield and Wire Guard

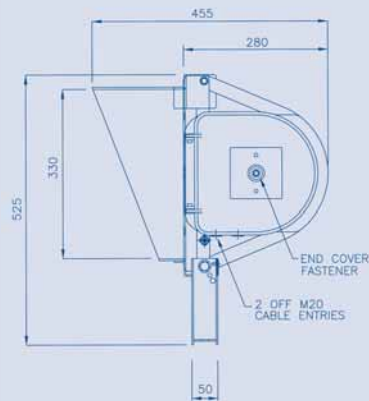

Swing Jib Damper & Bracket Assembly

Evolution only

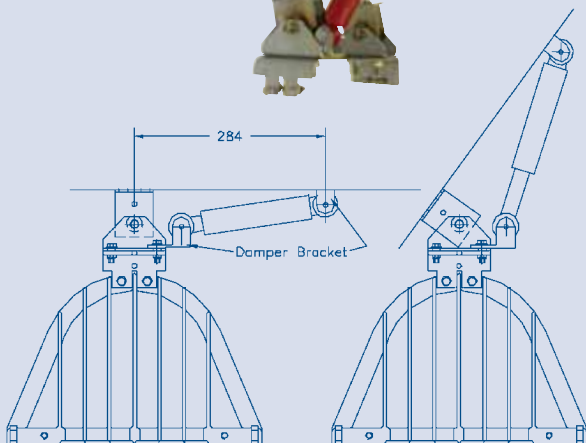
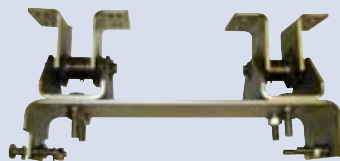

Damper assembly - SEV01-0015

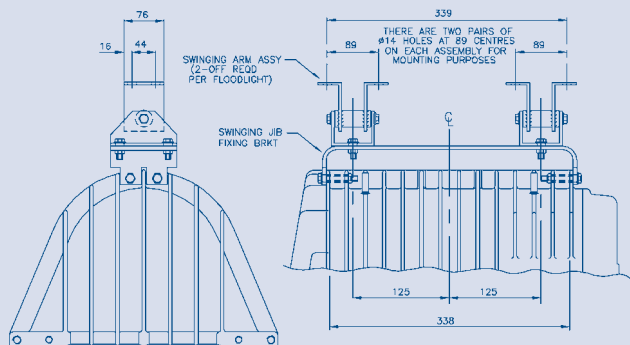

Bracket assembly - SEV04-0009

Pole Mounting Bracket Assembly

Cat No. SEVO4-0001

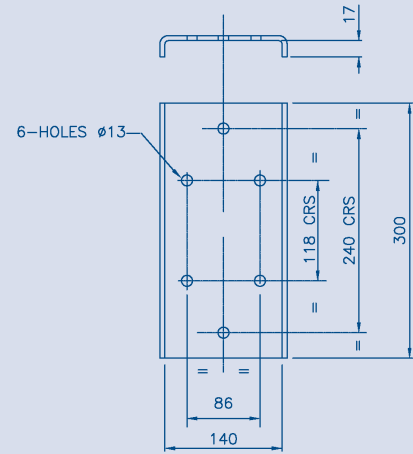
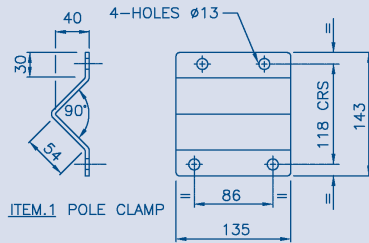

284 Retrofit Bracket

Cat No. SEVO1-0001

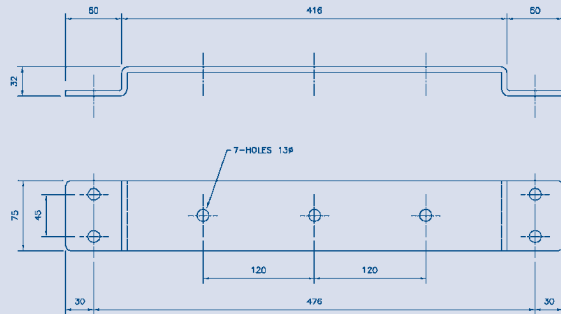

Evolution Junior Mounting Accessories

Cat No. SEVJR-0001/SEVJR-0002



Floor assembly SEVJR-0001



Tripod assembly SEVJR-0002