



The Pyramid is designed for low and medium bay applications where a high level of illumination and low glare is required. The high technology refractor gives excellent light distribution. The zinc coated steel body with polyester painting and the polycarbonate refractor make the Pyramid suitable for moderately aggressive locations where it can be surface mounted suspended or recessed. The Pyramid also has IP65 ingress protection.

It is particularly suitable for mounting under canopies, in warehouses and in factories. The Pyramid is also available with a dust cover configuration making it ideally suited for use in production areas where combustible dust (and gas) are present.

Standard Specification		Features
Type of Protection	Ex nR (Restricted Breathing) Dust protected enclosure	Zinc coated steel sheet, polyester painted for durability
ATEX Classification	Group II Category 3 G D	Polycarbonate prismatic lens with excellent light distribution
Area Classification	Zone 2 and Zone 22 areas to EN 60079-10 and EN 50281-3 with installation to EN 60079-14 and EN 50281-1-2	Suspended gear tray for ease of maintenance
Apparatus Standard	EN 50021 EN 50281-1-1	Simple and easy access via front cover for lamp replacement and maintenance
Certificate	EC Type Examination certificate BAS01ATEX3239	Excellent light distribution and uniformity up to 10 metre mounting heights
Coding	Ⓔ II 3 G D EEx nR II (refer to table for T rating and ambient)	Low glare
Enclosure	White polyester painted zinc coated steel body and front cover with silicone gasket and polycarbonate diffuser	<p style="text-align: center;">International Approvals</p> <p style="text-align: center;">ATEX</p>
Reflector/Geartray	High purity anodised aluminium	
Entry	2 x 20mm diameter holes	
Termination	3 core 6mm ² max. conductor with looping	
Installation	4 x 10mm clearance holes	
Lampholder	E40	
Control Gear	Internal copper/iron ballast with ignitor and PFC correction capacitors	
Relamping	Access via front cover secured by eight stainless steel screws	
Lamp Type	HPS or Metal Halide	
Ingress Protection	IP65 to EN 60529	
Electrical Supply	220, 230, 240, 254V 50Hz	

Std. Cat No.	Wattage	Lamp	TClass	T°(Dust)	Ambient °C	Weight
PYMN/150/HS	150W	HPS	T4	130	50	18.5kg
PYMN/150/HS/RE	150W	HPS	T4	130	45	18.5kg
PYMN/250/MS	250W	HPS/Metal Halide	T4	110	45	19.5kg
PYMN/250/MS/RE	250W	HPS/Metal Halide	T4	110	35	19.5kg
PYMN/400/MS	400W	HPS/Metal Halide	T4	115	30	21.0kg

Options – Suffix to Catalogue No.

/60	60Hz	/RE	Recessed (150 and 250W only)
/25	25mm cable entries	/SUS/D	Dust (& Gas) applications with rear dust shed
/SUS/G	Suspension/pendant mounting version (Gas applications only)	/TI	Timed cutout ignitor

Standard Configuration

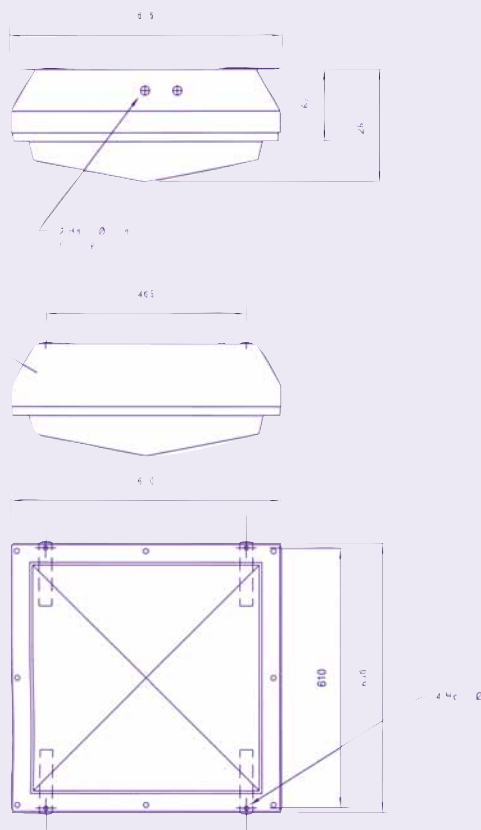

Dust applications with rear dust shed

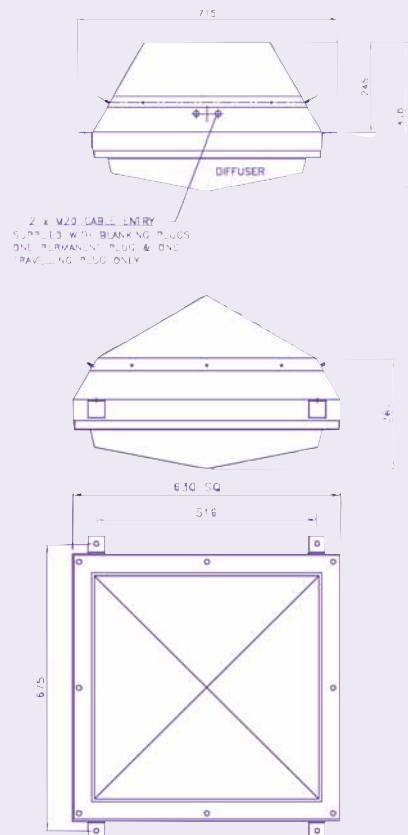

Accessories Should be ordered separately

Catalogue Order Code

There are no accessories for this product

